

TSUBAKI

POWER CYLINDER

**< F Series Parallel TYPE >
(1.00 through 1.50kN Thrust)**



- Thank you for purchasing TSUBAKI POWER CYLINDER.
- This product should be handled by experienced engineers only. Before using the Power Cylinder, you must read and understand the entire contents of this instruction manual.
- This manual should be considered a fixed part of the Power Cylinder and should remain with the Power Cylinder when sold.
- Units described herein are SI {Gravitational}. Figure in { } is for reference.

TSUBAKIMORO CHAIN CO.

<Safety Precautions>

Safety precautions in this manual are classified into two categories: WARNING and CAUTION.

These categories are defined as follows.

 WARNING	Death or serious injury may result from misusing the product without following the instructions under this label.
 CAUTION	Minor to moderate injury and damage to the product may result from misusing the product without following the instructions under this label.

Note that there is a possibility that an item listed under CAUTION may result in serious injuries.



WARNING

<General>

- Do not use POWER CYLINDER in an explosive atmosphere. Otherwise, explosion, ignition, electrical shock, injury or damage to the unit may result.
- Do not handle the POWER CYLINDER while the power is turned on. Switch off the power supply prior to operation in order to prevent electrical shocks.
- Transporting, installing, wiring, maintaining or inspecting must be carried out by skilled and professional engineers. Otherwise, explosion, electrical shock, injury or damage to the unit may result.
- When POWER CYLINDER is used for a passenger vehicle, install a suitable protection device on the vehicle. This can prevent accidents and equipment damages.
- When POWER CYLINDER is used for an elevator, install a safety device on the elevator in order to protect it from falling. Otherwise, accidents resulting in death, injury or equipment damage may result.

<Transportation>

- Never stand under the product when it is lifted for transportation. Otherwise, the product may fall and cause major accidents resulting in death or injury.

<Wiring>

- Connect power cable according to the wiring diagram in this instruction manual. Otherwise electrical shock or fire may result. (Be sure to insulate the connection.)
- Do not bend, pull or pinch the power cable or motor lead wires to avoid possible electrical shocks.

<Operation>

- Always supply power voltage as specified on the nameplate to prevent possible fire or burnouts.
- Do not operate a machine while the lead wire is not insulated. Otherwise, electrical shock may occur.
- Avoid contacts with rotating parts such as the shaft during operation. Otherwise, approaching objects or body parts can catch on a rotating part and result in serious injury.
- Be sure to turn off the power in times of power failure. Power may restore without notice and injure a personnel or damage the device.

<Daily Inspection and Maintenance>

- When carrying out inspection or maintenance during operation, avoid contacts with the rod and rotating parts (i.e. manual shaft etc.). Otherwise, accidents resulting in death or injury may occur.
- Do not remove the inspection cover during operation. Hot oil may splash and cause burns.
- When inspecting gear teeth or screw while the motor is stopped, perform only after the rotation of the driving and driven sections are also completely stopped. Otherwise accidents resulting in death or injury may occur.
- When performing an internal inspection make sure the motor and all the units are stopped completely, and that the inside of the machine is cool enough and well ventilated.
Set personnel outside of the product to supervise and support the person inspecting inside.
You must lubricate the internal parts and take safety measures to prevent accidents such as slipping.

Thank you for purchasing TSUBAKI POWER CYLINDER.
POWER CYLINDER F Series Parallel Type has superior features compared to pneumatic, hydraulic, and other commonly used linear actuators. To obtain optimum performance from this mechanically and electronically sophisticated unit, careful attention to the contents of this manual is required. This operation manual also provides installation and maintenance information. Read and follow the contents carefully and pay special attention to details on inspection, handling, and maintenance.

<Contents>

1. Verifying the delivered unit	---	P 1
2. Installation	---	P 2
3. Wiring	---	P 3
4. Precautions	---	P 5
5. Maintenance and Inspection	---	P 6
6. Warrantee	---	P 7

1. Verify the following upon receiving your POWER CYLINDER

- (1) Confirm that the type, thrust (rated load), speed, stroke, voltage (DC12V or 24V) and other specifications printed on the nameplate and the attached accessories correspond to your requirements.
- (2) Check whether any part of the product has been damaged during delivery.
- (3) Check whether the screws, bolts and connector of lead wires are fastened securely.

Make sure any damages done to the POWER CYLINDER during shipment are immediately reported to your distributor, or TSUBAKIMOTO CHAIN with the MFG No.

2. Installation.

Correct installation is essential for an effective and long service life of the POWER CYLINDER.

(1) Ambient environment

Installation location	Indoor or outdoor with outdoor specification connector.
Atmosphere	Dust level should be same as normal factory.
Ambient temperature	-5°C ~ +40°C
Shock	Below 1G
Ambient humidity	85% max. (no condensation)

(2) Never twist or apply force to bend the rod (lateral load).

(3) Use a 12 to 12.4 mm diameter pin at both the rod and clevis end to connect the equipment.

Use a greased pin with a smooth surface to prevent the holes from wearing.

(4) When the POWER CYLINDER swings during operation, set the pins at the rod and clevis end in parallel to each other. Make sure the tip of the rod and the clevis end do not interfere with the mounting portion of the equipment.

Ambient temperature is usually -5 °C~+40°C. Note that low temperature may affect the unit performance.

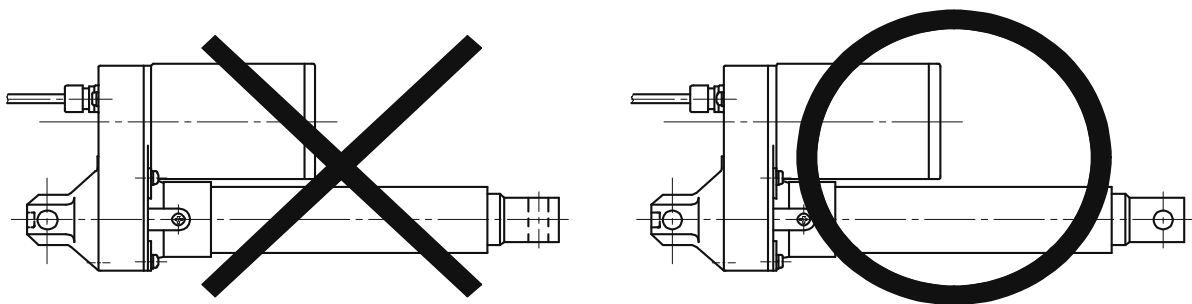

(5) Prevention of rod rotation

The rod builds up rotational force from the thrust. Prevent this rotation by installing an appropriate device on your equipment.

	LPF100MK	LPF150LK
Torque N · m {kgf · c m}	1.67 {17}	2.55 {26}

3. Wiring

(1) Use the connectors below to connect the power source and actuator.

YAZAKI CN Connector Z Pole F Type (Part No. 7123-2024)

Terminal F Type (Part No. 7116-2090) 2 pcs.

(2) Relationship between rod actuation and wiring

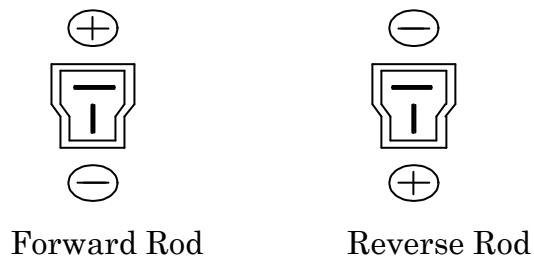

(3) Power source capacity

Power source must be sufficient to cover rated current of approximately 16 A at DC 12V for the POWER CYLINDER. When the power source is insufficient, the unit may not perform at the specified actuation and speed. (For DC 24V, the rated current is approximately 8A.)

(4) Although wire diameter varies with length, use approximately 2 mm² for 5 to 6 m wires. If thin wire is used, performance may be affected by possible voltage drop.

(5) Operational diagram

① Refer to the diagram below for inching operation.

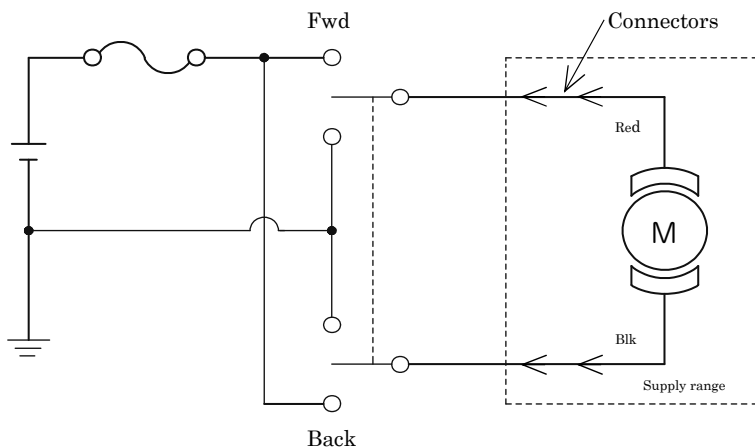

DPDT (Double Poles Double Throw), Center off position, Lever with MOMENTARY both side.

- ① For manual operation, control strokes by using limit switches or a mechanical stopper.

To reduce the amount of coasting, the method described in the below diagram, which is effective with dynamic braking, is recommended.

(Dynamic braking diagram: A circuit that activates braking pressure by shortening the circuits at both terminals of the motor, right after the motor switch is turned off.)

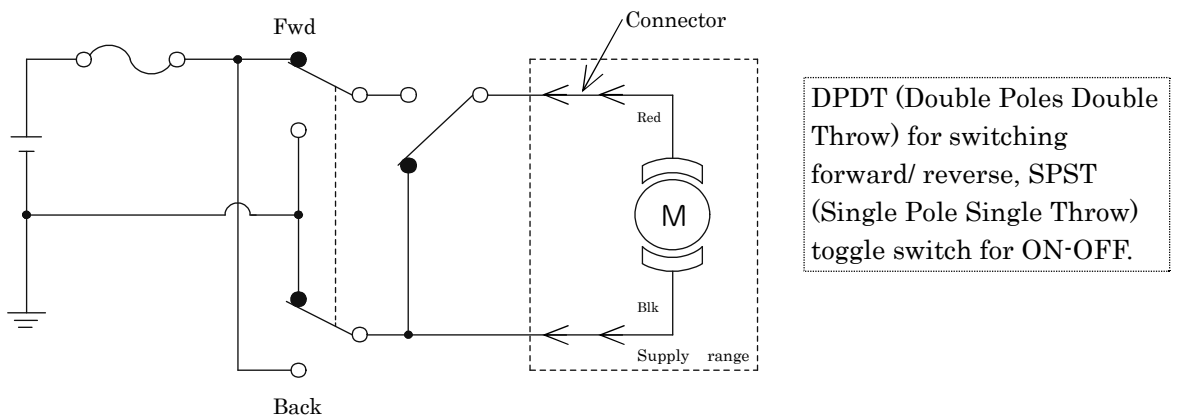

- ③ Set limit switches at both ends of stroke to establish a remote or automated control. The unit may be directly turned on or off. However, the contact points may be damaged due to the large current.

To reduce the amount of coasting, the method described in the above diagram, which is effective for dynamic braking, is recommended as in ②.

- (6) Select fuse that can cut off within 2 to 3 seconds at 200% of rated current to prevent burnouts

4. Precautions

(1) Ball clutch

A ball clutch is installed into each POWER CYLINDER unit for overload protection. Do not always use the ball clutch to control the stroke range: it should be used to protect against overload. Ball clutch performance may decrease by using it to stop strokes or in the case of large inertia, the screw and nut may become stuck and affect the operation. Each ball clutch is set at 150% of the rated thrust, and when it is activated, the unit will make clicking noises. These clicks indicate an overload condition, which requires you to stop the operation immediately and to remove the cause of overload. The current may drop 70% of rated value while the ball clutch operating. However, this is not abnormal. A prolonged period of ball clutch operation may result in reduced performance due to wear and tear of the parts or other reasons depending on individual situations.

(2) Coasting

After stopping the motor, the cylinder rod will coast a little due to motor inertia. The amount of this coasting will depend on the Model No. and loading condition. Set the limit switches accordingly. If minimum coasting is required when stopping the unit in the middle of a stroke, dynamic braking method (regenerative braking) is recommended.

	No load	Rated load
LPF100MK	Approx. 20mm	Approx. 10mm
LPF150LK	Approx. 15mm	Approx. 7mm

(3) Holding the load

Load holding capability of POWER CYLINDER is 1 ton or more for static loads. However, the rod may move gradually with vibration or shock loads. Avoid loads with vibration or shock.

(4) Operational frequency

This cylinder is suitable for low frequency operation.

Use a motor starting at 2 rotations/ min. or less and 25% ED (5 min. basis) or less.

Expected life is 20,000 travels (counting forward and back as one travel).

(5) Power source

In cases where a battery is not used, and AC is rectified to DC, make sure to use a full wave rectification and use a sufficient DC power source that will not drop the voltage. Otherwise, the performance of the cylinder and the life of brush will be affected.

(6) Environments with water

Keep the connector away from water. Be sure to use a waterproof connector in cases where damage by water is possible.

(7) Cold temperatures

Cylinder speed may decrease and current may increase under cold temperatures.

5. Maintenance and inspection

Actuator and reducer portions of this POWER CYLINDER are pre-lubricated with grease thus additional greasing is not necessary.

If you desire to use over the expected life of 20,000 travels, consult TSUBAKIMOTO CHAIN.

Warranty:

TSUBAKIMOTO CHAIN Co.: hereinafter referred to as "Seller"

Customer: hereinafter referred to as "Buyer"

Goods sold or supplied by Seller to Buyer: hereinafter referred to as "Goods"

1. Warranty period without charge

18 months effective the date of shipment or 12 months effective the first use of Goods, including installation of Goods to Buyer's equipment or machines - whichever comes first.

2. Warranty coverage

Should any damage or problem with the Goods arise within the warranty period, given that the Goods were operated and maintained under instructions provided in the manual, Seller will repair and replace at no charge once the Goods are returned to the Seller. This warranty does not cover the following:

- (1) Any costs related to removal of Goods from the Buyer's equipment or machine to repair or replace parts.
- (2) Costs to transport Buyer's equipment or machine to the Buyer's repair shop.
- (3) Costs to reimburse any profit loss due to any repair or damage and other consequential losses caused by the Buyer.

3. Warranty with charge

Seller will charge any investigation and repair of Goods caused by:

- 1) Improper installation by failing to follow the instruction manual.
- 2) Insufficient maintenance or improper operation by the Buyer.
- 3) Incorrect installation of Goods to other equipment or machine.
- 4) Any modifications or alterations of Goods by the Buyer.
- 5) Any repair by engineers other than the Seller or those designated by the Seller.
- 6) Operation in an inappropriate environment not specified in the manual.
- 7) Force Majeure or forces beyond the Seller's control such as natural disasters and injustice done by a third party.
- 8) Secondary damage or problem incurred by the Buyer's equipment or machine.
- 9) Defected parts supplied, or specified by the Buyer.
- 10) Incorrect wiring or parameter setting by the Buyer.
- 11) The end of life cycle of the Goods under normal usage.
- 12) Loss or damage not liable to the Seller.

4. Dispatch service

Service to dispatch a Seller's engineer to investigate, adjust or trial test Seller's Goods is at the Buyer's expense.

5. Disclaimer

- 1) In our constant efforts to improve, TSUBAKIMOTO CHAIN Co. may change the contents of this document without notice.
- 2) Considerable effort has been made to ensure that there are no errors in the contents of this manual. However, any errors or inaccuracies reported to us will be gladly examined and amended as necessary.



TSUBAKIMOTO CHAIN CO.

1-1, Kohtari-Kuresumi, Nagaokakyo

Kyoto 617-

0833, Japan

Website: <http://tsubakimoto.com/>

Global Associated Partners:

U.S. Tsubaki Power Transmission, LLC

<http://www.ustsubaki.com/>

Tsubakimoto Singapore Pte. Ltd.

<http://tsubaki.sg/>

Tsubakimoto Europe B.V.

<http://tsubaki.eu/>

Tsubaki of Canada Limited

<http://tsubaki.ca/>

Taiwan Tsubakimoto Co.

<http://tsubakimoto.com.tw/>

Tsubakimoto U.K. Ltd.

<http://tsubaki.eu/>

Tsubaki Australia Pty. Limited

<http://tsubaki.com.au/>

Tsubakimoto Chain (Shanghai) Co., Ltd.

<http://tsubaki.cn/>

Tsubakimoto Korea Co., Ltd..

<http://tsubakimoto-tck.co.kr/>