

TSUBAKI

POWER CYLINDER

< F Series Parallel TYPE >
(Under 400N Thrust)



- Thank you for purchasing TSUBAKI POWER CYLINDER.
- This product should be handled by experienced engineers only. Before using the Power Cylinder, you must read and understand the entire contents of this instruction manual.
- This manual should be considered a fixed part of the Power Cylinder and should remain with the Power Cylinder when sold.
- Units described herein are SI {Gravitational}. Figure in { } is for reference.

TSUBAKIMOTO CHAIN CO.

TSUBAKI
POWER CYLINDER F-Series Parallel Type
〈Under 400N Thrust〉

Safety Precautions

Safety precautions in this manual are classified into two categories: WARNING and CAUTION. These categories are defined as follows.

| | |
|--|--|
|  WARNING | Death or serious injury may result from misusing the product without following the instructions under this label. |
|  CAUTION | Minor to moderate injury and damage to the product may result from misusing the product without following the instructions under this label. |

Note that there is a possibility that an item listed under CAUTION may lead to serious injury.

WARNING

<General>

- Do not use POWER CYLINDER in an explosive atmosphere. Otherwise, explosion, ignition, electrical shock, injury or damage to the unit may result.
- Do not handle the POWER CYLINDER while the power is turned on. Switch off the power supply prior to operation in order to prevent electrical shocks.
- Transporting, installing, wiring, maintaining or inspecting must be carried out by skilled and professional engineers. Otherwise, explosion, electrical shock, injury or damage to the unit may result.
- When POWER CYLINDER is used for a passenger vehicle, install a suitable protection device on the vehicle. This can prevent accidents and equipment damage.
- When POWER CYLINDER is used for an elevator, install a safety device on the elevator in order to protect it from falling. Otherwise, accidents resulting in death, injury or equipment damage may result.

<Transportation>

- Never stand under the product when it is lifted for transportation. Otherwise, the product may fall and cause major accidents resulting in death or injury.

<Wiring>

- Connect power cable according to the wiring diagram in this instruction manual and be sure to insulate the connection. Failure to do so may result in electrical shock or fire.
- Do not bend, pull or pinch the power cable or motor lead wires to avoid possible electrical shocks.

<Operation>

- Always supply power voltage as specified on the nameplate to prevent possible fire or burnouts.
- Do not operate your machine while the lead wire is not insulated. Otherwise, electrical shock may occur.
- Avoid contacts with rotating parts such as the shaft during operation. Otherwise, approaching objects or body parts can catch on a rotating part and result in serious injury.
- Be sure to turn off the power in times of power failure. Power may restore without notice and injure a personnel or damage the device.

<Daily Inspection and Maintenance>

- When carrying out inspection or maintenance during operation, avoid contacts with the rod and rotating parts such as the manual shaft. Otherwise, accidents resulting in death or injury may occur.
- Do not remove the inspection cover during operation. Hot oil may splash and cause burns.
- Verify that the driving and driven sections have completely stopped rotating before inspecting gear teeth while the motor is turned off. Otherwise accidents resulting in death or injury may occur.
- When performing an internal inspection make sure the motor and all the units are completely stopped, and that the inside of the machine is cool enough and well ventilated. Set personnel outside of the product to supervise and support the person inspecting inside.
- Lubrication of internal parts must be conducted and be accompanied by safety measures to prevent accidents such as slipping.

< General >

- Do not use the POWER CYLINDER beyond the capacity specified on its nameplate or specification sheet. Otherwise electrical shock, injury, damage to the equipment may result.
- Do not insert your fingers or objects in the POWER CYLINDER opening. Otherwise

electrical shock, injury, fire or equipment damage may result.

- Do not use a damaged POWER CYLINDER. Doing so may result in injury or fire.
- Do not remove the nameplate.
- Problems caused by your attempts to remodel the product are not covered by our warranty, and are therefore, not held responsible by TSUBAKI E&M.
- Use the POWER CYLINDER within the allowable stroke. Over stroke may result in unit failure.
-

< Upon receipt of your POWER CYLINDER >

- Be sure the package is in its upright position prior to opening.
- Verify that the POWER CYLINDER you received corresponds to your order. If an incorrect product is installed to your equipment, injury, damage to the equipment may result.

CAUTION

<General>

- Do not use POWER CYLINDER beyond its capacity specified on the nameplate or specification sheet. Otherwise, explosion, electrical shock, injury or damage to the equipment may result.
- Do not insert fingers or objects into the POWER CYLINDER opening. Otherwise, electrical shock, injury, fire or equipment damage may result.
- Do not use a damaged POWER CYLINDER as this may cause fire or injury.
- Do not remove the nameplate.
- Problems caused by your attempts to remodel the product are not covered by our warranty, and are therefore, not held responsible by TSUBAKI E&M.
- Use the POWER CYLINDER within the allowable stroke. Over stroke may result in unit failure.
- <Upon Delivery>
- Be sure the package is in its upright position prior to opening.
- Be sure the product delivered matches your order. This will prevent you from accidents, injuries or equipment damage caused by installing the wrong unit.

<Transportation >

- When transporting your equipment, take caution so that it does not fall or overturn.
- Be sure that the weight of the POWER CYLINDER, as specified in the diagram and catalog provided, does not exceed the maximum rate assigned to the lifting device. Otherwise, the device may break and damage the equipment.

<Installation >

- Do not place any flammable objects around the POWER CYLINDER. Otherwise fire may occur.
- Do not place any obstacles which may block the ventilation around the POWER CYLINDER. Otherwise, POWER CYLINDER may overheat and cause fire.
- Do not climb or hang on to the POWER CYLINDER. Otherwise injury may occur.

<Lubricant >

- When POWER CYLINDER is used for food processing machines, install a device such as an oil pan to avoid the lubricant from leaking into food products.

<Wiring >

- Verify that the limit switch wiring and travel stroke are appropriate prior to operation. Otherwise injury or damage to the equipment may result.
- Do not touch the terminals when measuring the insulation resistance. Otherwise electrical shock may occur.
- Wire according to the general technical standards of electrical installation or those set forth by your company. Otherwise burnout, electrical shock, fire or injury may result.
- POWER CYLINDERS are not equipped with a protection device. Installation of an overload protection device is mandatory under the technical standards of Electrical Installation. Installation of other protection devices—such as ground-fault circuit breakers, etc.—in addition to the overload protection device is recommended. Without these devices, physical damage, electrical shock, fire or injury may result.
- Before installing a POWER CYLINDER to another machine, check the rod's traveling direction. Incorrect traveling direction may cause injury or damage the equipment.
- Use a wire within 5 to 6 m and 2 mm² in diameter or larger. Long distance wiring may result in voltage drop and prevent the POWER CYLINDER from starting.
- Verify that the motor has completely stopped running, before reversing the rotation direction. Otherwise, equipment damage may result.

< Operation >

- During operation, the surface temperature of POWER CYLINDER will become considerably high. Do not touch the unit with bare hands. Otherwise burn injury may occur.
- Stop the operation immediately when you suspect any problems. Otherwise electrical shock, injury or fire may result.
- Do not exceed the rated maximum load. Otherwise, injury, your equipment or POWER CYLINDER damage may result.

< Maintenance and Safety Check >

- Do not touch the terminals when measuring the insulation resistance. Otherwise electrical shock may occur.
- The surface temperature of POWER CYLINDER will become considerably high. Do not touch the unit with bare hands. Otherwise burn injury may occur.
- Do not change the lubricant during operation or immediately after stopping the motor. Otherwise burn injury may occur.
- For abnormal situations, carry out diagnosis according to the instruction manual. Never resume operation until you investigate the cause of the problem.

< Disassembly and Assembly >

- Repair, disassembly and assembly of POWER CYLINDER must be handled by specialists. Otherwise, electrical shock, injury or fire may result.

< Scrapping >

- When scrapping the POWER CYLINDER or disposing the lubricant, dispose as general waste.

Thank you for purchasing TSUBAKI POWER CYLINDER.
POWER CYLINDER F Series Parallel Type has superior features compared to pneumatic, hydraulic, and other commonly used linear actuators. To obtain optimum performance from this mechanically and electronically sophisticated unit, carefully read and follow the contents of this manual. Pay special attention to details on inspection, handling, and maintenance.

<Contents>

| | | | |
|---------------------------------|-----|---|---|
| 1. Verifying the delivered unit | --- | P | 2 |
| 2. Installation | --- | P | 2 |
| 3. Wiring | --- | P | 3 |
| 4. Precautions | --- | P | 4 |
| 5. Maintenance and Inspection | --- | P | 4 |
| 6. Warrantee | --- | P | 5 |

1. Verify the following upon receiving your POWER CYLINDER

- (1) Model type, thrust (rated load), speed, stroke and voltage.

Check whether the screws, bolts and connector of lead wires are fastened securely. (DC12V or 24V) and other specifications printed on the nameplate and the attached accessories correspond to your requirements.

- (2) The screws, bolts and connector lead wires are securely in place.
 (3) No damage has been done to the product during transportation.

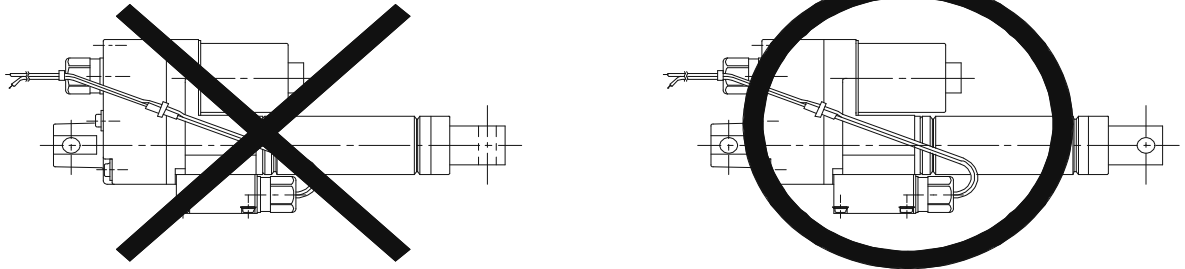

Immediately report any damage done to the POWER CYLINDER during shipment to your distributor, or TSUBAKIMOTO CHAIN with the MFG No.

2. Installation.

Correct installation is essential for an effective long service life of the POWER CYLINDER.

Ambient Environment

| | |
|-----------------------|---|
| Installation Location | Indoor or outdoor with outdoor specification connector. |
| Atmosphere | Dust volume should be normal. |
| Ambient Temperature | -5°C ~ +40°C |
| Shock | Below 1G |
| Ambient Humidity | 85% max. (no condensation) |

Ambient temperature is usually -5 °C~+40°C. Note that low temperature may affect the unit performance.

- (1) Never twist or apply force (lateral load) to bend the rod.
 (2) Use an 8 mm diameter d9 tolerance pin at both the rod and clevis end to connect the equipment.
 Use a greased pin with a smooth surface to prevent the holes from wearing.
 (3) If the POWER CYLINDER swings during operation, set the pins at the rod and clevis end in parallel to each other. Make sure the tip of the rod and the clevis end do not interfere with the mounting portion of the equipment.
 (4) This cylinder has built-in springs in the actuator portion so that mechanical stopping is possible.
 When the POWER CYLINDER is mechanically stopped, MAX.245N{25kgf} may act on LPFAO1OMK, while MAX.784N{80kgf} may act on LPFO4OLK. Thus the strength of the installation portion must be verified.

(5) Preventing Rod Rotation

The rod builds up rotational force from the thrust. Prevent it from rotating by installing an appropriate device on your equipment.

| | | |
|-------------------------|------------|-----------|
| | LPF010MK | LPF040LK |
| Torque N • m {kgf • cm} | 0.317 {32} | 0.98 {10} |

3. Wiring

(1) Use the connectors below to connect the power source and actuator outdoors.
AMP Mark II or equivalent.

(2) Relationship between Rod Actuation and Wiring

| Actuation Direction | Power Source | Lead Wire Color |
|---------------------|--------------|-----------------|
| Forward | + | Red |
| | - | Black |
| Reverse | + | Black |
| | - | Red |

(3) Power Source Capacity

Power source must be sufficient to cover rated current of approximately 3.2 A at DC 12V for the POWER CYLINDER. When the power source is insufficient, the unit may not perform at the specified actuation and speed. (For DC 24V, the rated current is approximately 1.6 A.)

(4) Although wire diameter varies with length, use approximately 1.25 mm² for 5 to 6 m wires. If thin wire is used, performance may be affected due to possible voltage drop.

(5) Operational Diagram

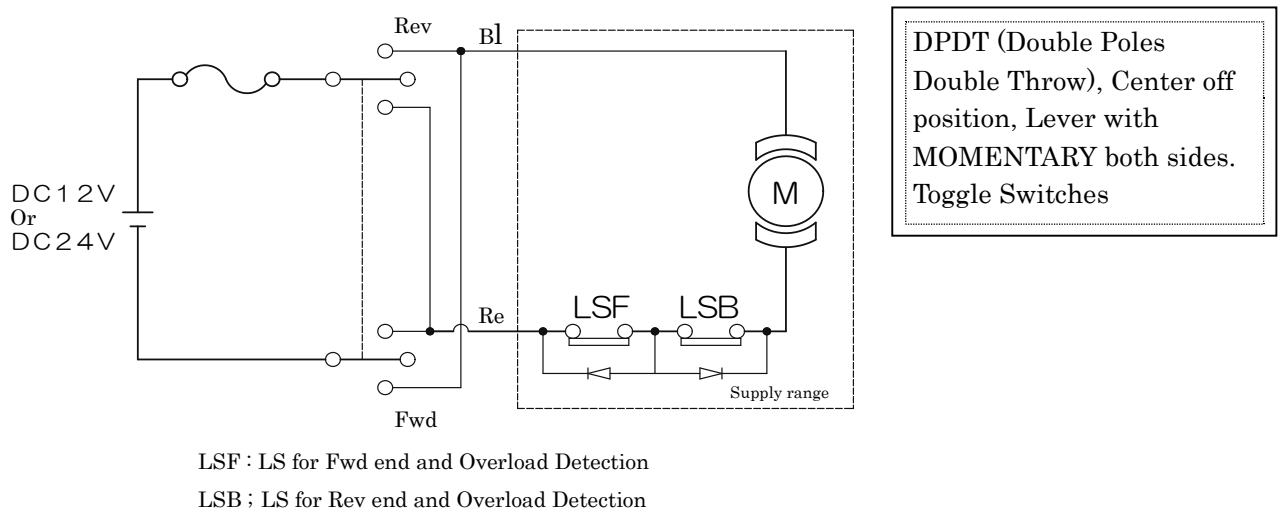

- (6) Select fuse that can cut off within 2 to 3 seconds at 200% of rated current to prevent burnouts. Fuse capacity for DC12V is 5A while that for DC24V is 3A.
- (7) It is possible to mechanically stop the POWER CYLINDER with built-in limit switches. However, make sure that voltage is not constantly applied to the red and black lead wires. If vibration exceeds 1G, the springs may loosen, the LS may reset and the motor may re-start.

4. Precautions

(1) Coasting

After stopping the motor, the cylinder rod will coast a little due to motor inertia. The amount of this coasting will depend on the Model No. and loading condition. Set the limit switches accordingly. If minimum coasting is required when stopping the unit in the middle of a stroke, dynamic braking method (regenerative braking) is recommended.

(2) Holding the Load

Load holding capability of POWER CYLINDER is strong enough for 300% of the rated load for static loads. However, the rod may move gradually with vibration or shock loads. Avoid loads with vibration or shock. (A brake for the unit is not available.)

(3) Operational Frequency

This cylinder is suitable for low frequency operation.

Use a motor starting at 2 rotations/ min. or less and 25% ED (5 min. basis) or less.

Expected life is 20,000 travels. (Count back-and-forth as one travel.)

(4) Power Source

In cases where a battery is not used, and AC is rectified to DC, make sure to use a full wave rectification and use a sufficient DC power source that will not cause a voltage drop. Otherwise, the performance of the cylinder and the life of brush will be affected

(5) Water Environments

Use a waterproof connector.

(6) Grease Spill at Rod Sliding Portion

When mechanically stopping the POWER CYLINDER using the built-in limit switches, the grease inside the unit will spill as rod moves forward. This, however, shall not affect the unit performance.

5. Maintenance and Inspection

Actuator and reducer portions of this POWER CYLINDER are pre-lubricated with grease thus additional greasing is not necessary.

If you desire to use over the expected life of 20,000 travels, consult TSUBAKIMOTO CHAIN.

Warranty:

TSUBAKIMOTO CHAIN Co.: hereinafter referred to as "Seller"

Customer: hereinafter referred to as "Buyer"

Goods sold or supplied by Seller to Buyer: hereinafter referred to as "Goods"

1. Warranty period without charge

18 months effective the date of shipment or 12 months effective the first use of Goods, including installation of Goods to Buyer's equipment or machines - whichever comes first.

2. Warranty coverage

Should any damage or problem with the Goods arise within the warranty period, given that the Goods were operated and maintained under instructions provided in the manual, Seller will repair and replace at no charge once the Goods are returned to the Seller. This warranty does not cover the following:

- (1) Any costs related to removal of Goods from the Buyer's equipment or machine to repair or replace parts.
- (2) Costs to transport Buyer's equipment or machine to the Buyer's repair shop.
- (3) Costs to reimburse any profit loss due to any repair or damage and other consequential losses caused by the Buyer.

3. Warranty with charge

Seller will charge any investigation and repair of Goods caused by:

- (1) Improper installation by failing to follow the instruction manual.
- (2) Insufficient maintenance or improper operation by the Buyer.
- (3) Incorrect installation of Goods to other equipment or machine.
- (4) Any modifications or alterations of Goods by the Buyer.
- (5) Any repair by engineers other than the Seller or those designated by the Seller.
- (6) Operation in an inappropriate environment not specified in the manual.
- (7) Force Majeure or forces beyond the Seller's control such as natural disasters and injustices done by a third party.
- (8) Secondary damage or problem incurred by the Buyer's equipment or machine.
- (9) Defected parts supplied, or specified by the Buyer.
- (10) Incorrect wiring or parameter setting by the Buyer.
- (11) The end of life cycle of the Goods under normal usage.
- (12) Loss or damage not liable to the Seller.

4. Dispatch service

Service to dispatch a Seller's engineer to investigate, adjust or trial test Seller's Goods is at the Buyer's expense.

5. Disclaimer

- (1) In our constant efforts to improve, TSUBAKIMOTO CHAIN Co. may change the contents of this document without notice.
- (2) Considerable effort has been made to ensure that the contents of this document are free from errors. However, TSUBAKI E&M Co. makes no warranties with respect to the accuracy of information described herein. In the mean time, we would appreciate comments or reports on any inaccuracies or omissions in regards to this document to help us make amendments as necessary. Your cooperation is greatly appreciated.



TSUBAKIMOTO CHAIN CO.

1-1, Kohtari-Kuresumi, Nagaokakyo
Kyoto 617- 0833, Japan
Website: <http://tsubakimoto.com/>

Global Associated Partners:

U.S. Tsubaki Power Transmission, LLC
<http://www.ustsubaki.com/>

Tsubakimoto Singapore Pte. Ltd.
<http://tsubaki.sg/>

Tsubakimoto Europe B.V.
<http://tsubaki.eu/>

Tsubaki of Canada Limited
<http://tsubaki.ca/>

Taiwan Tsubakimoto Co.
<http://tsubakimoto.com.tw/>

Tsubakimoto U.K. Ltd.
<http://tsubaki.eu/>

Tsubaki Australia Pty. Limited
<http://tsubaki.com.au/>

Tsubakimoto Chain (Shanghai) Co., Ltd.
<http://tsubaki.cn/>

Tsubakimoto Korea Co., Ltd..
<http://tsubakimoto-tck.co.kr/>