

TSUBAKI REDUCER FOR SERVO MOTORS TERVO



GMTK L



HMTK H



GMTK U



SWJMK, SWMK

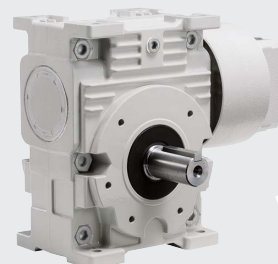

EWJMK, EWMK



Tsubaki's TERVO converts equipment to servo drive.

Wide-ranging lineup of gears

- Helical gears
- Hypoid gears
- Worm gears

Highly versatile

- Right-angle shaft or parallel shaft + solid or hollow
- Support for the servo motors of various companies

Economical

- Converts general-purpose gear heads to servo drive, which affords better economic efficiency and shorter delivery

→ TERVO Reducers



GMTK L type
Helical gear head



GMTK U type
Helical gear head



HMTK H type
Hypoid gear head



SWJMK/SWMK type
Worm gear head

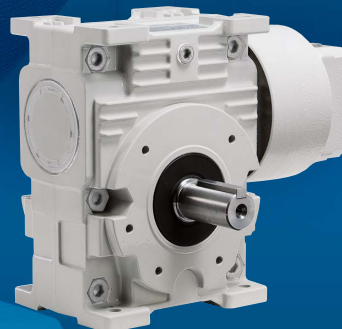

EWJMK/EWMK type
Worm gear head

Standardized clamp for servo motors



Tsubaki Reducer for Servo Motors

Positioning

Arrangement

Gears

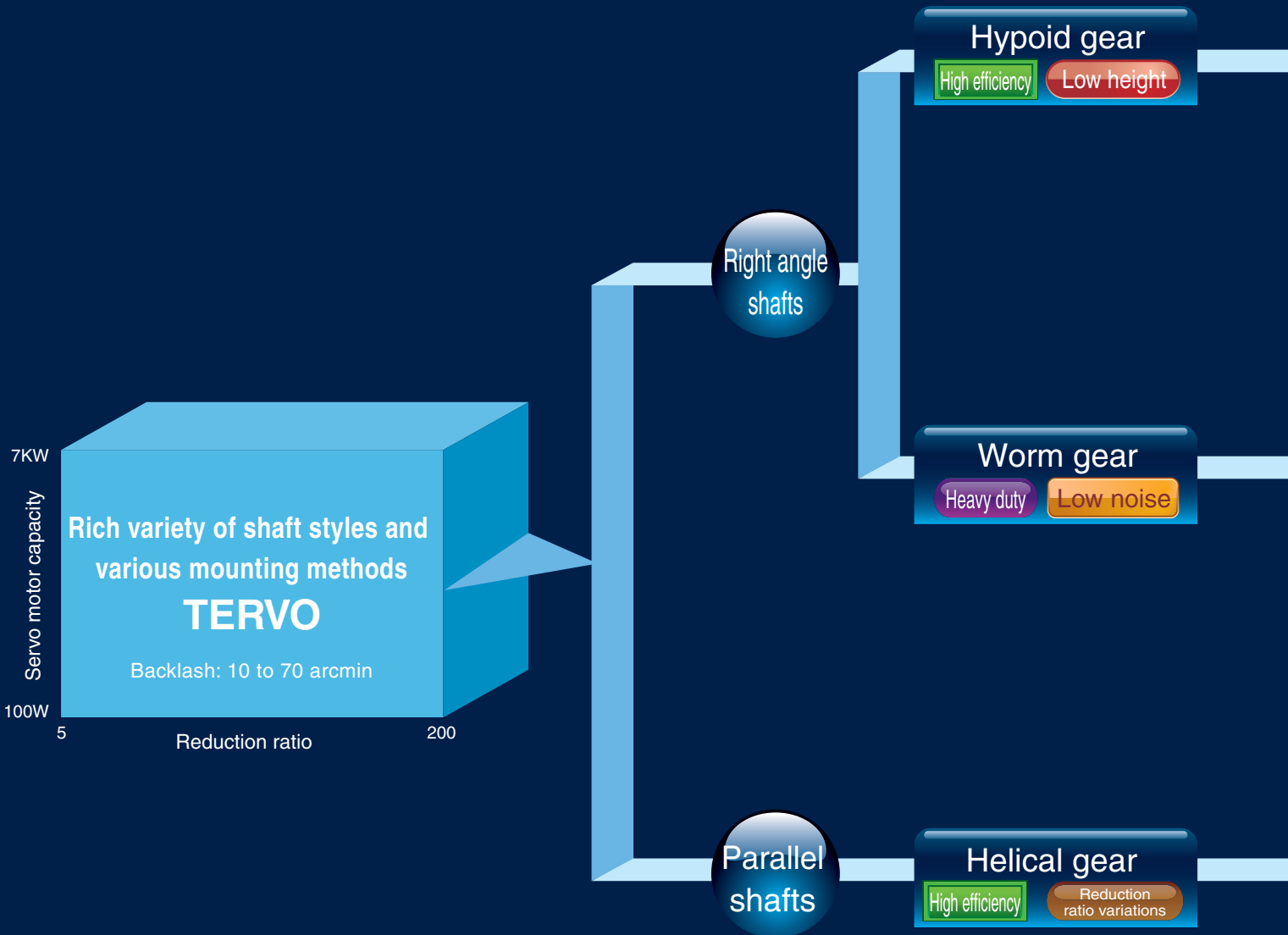

Selection Guide

Output shaft style

Type

Model range

Hollow shaft



Hypoid gear head
HMTK H

0.2 to 2kW

Page 15

Solid shaft



Hypoid gear head
HMTK U

0.2 to 2kW

Page 15

Hollow shaft



Worm gear head
SWJMK, SWMK

0.2 to 7kW

Page 23

Solid shaft



Worm gear head
EWJMK, EWMK

0.2 to 7kW

Page 25

Solid shaft

Face mount,
flange installation



Helical gear head
GMTK U, GMTK F

0.2 to 2kW

Page 19

Solid shaft

Foot mount



Helical gear head
GMTK L

0.2 to 2kW

Page 19

Standard Specifications

1. Hypoid gear head HMTK type and helical gear head GMTK type

Reducer	Reduction ratio	5 to 200
	Lubrication	Grease
	Output shaft key	Solid shaft: new JIS key (JIS B1301-1976), hollow shaft: new JIS keyway, key supplied for solid shaft
	Color	Light gray (Munsell N7.5)
	Rust proofing specifications	Rust proof effective for 6 months (after shipping) when stored indoors
Ambient conditions	Installation location	Indoors free of dust and water
	Ambient temperature	0 °C to 40 °C
	Ambient humidity	85 % or less (no condensation)
	Altitude	No more than 1,000 m above sea level
	Atmosphere	Area must be free of corrosive and explosive gases and steam.
	Mounting direction	The product can be installed horizontally, vertically, or at an angle. There are no limits on the installation angle.

Note) Regarding the ambient conditions, use the product within the ranges supported by the servo motor on which the product is mounted.

2. Worm gear head SWJMK/SWMK and EWJMK/EWMK types

Reducer	Reduction ratio	10 to 60
	Lubrication	Oil lubrication (specified oil)
	Output shaft key	Solid shaft: new JIS key (JIS B1301-1976), hollow shaft: new JIS keyway, key supplied for solid shaft
	Color	Light gray (Munsell N7.5)
	Rust proofing specifications	Rust proof effective for 6 months (after shipping) when stored indoors
Ambient conditions	Installation location	Indoors free of dust and water
	Ambient temperature	0 °C to 40 °C
	Ambient humidity	85 % or less (no condensation)
	Altitude	No more than 1,000 m above sea level
	Atmosphere	Area must be free of corrosive and explosive gases and steam.
	Mounting direction	The product can be installed horizontally or vertically (models SWJMK35 to SWJMK70 and EWJMK35 to EWJMK70 can be installed in any direction).

Note) Regarding the ambient conditions, use the product within the ranges supported by the servo motor on which the product is mounted.

Models

1. Hypoid gear head HMTK type

Reduction ratio / Motor capacity	5	10	15	20	25	30	40	50	60	80	100	120	160	200
0.2kW	HMTK0220H/0222U									HMTK0230H/0228U				
0.4kW	HMTK0430H/0428U						HMTK0435H/0438U							
0.75kW	HMTK0735H/0738U						HMTK0745H/0742U							
1.5kW	HMTK1545H/1542U									HMTK1555H/1550U				
2.2kW	HMTK2245H/2242U									HMTK2255H/2250U				

2. Helical gear head GMTK type

Reduction ratio / Motor capacity	5	10	15	20	25	30	40	50	60	75	100	120	165	200
0.2kW	GMTK0218U/L					GMTK0224U/L					GMTK0228U/L			
0.4kW	GMTK0424U/L					GMTK0428U/L					GMTK0438U/L			
0.75kW	GMTK0728U/L					GMTK0738U/L					GMTK0742F/L			

Reduction ratio / Motor capacity	5	10	20	25	30	40	60	75
1.5kW	GMTK1538U/L					GMTK1542F/L		
2.2kW	GMTK2242F/L		GMTK2242F/L		GMTK2242F/L			

3. Worm gear head SWJMK/SWMK and EWJMK/EWMK types

Upper half: SWJMK/SWMK
Lower half: EWJMK/EWMK

Reduction ratio / Size	10	15	20	25	30	40	50	60
35	0.38	0.30	0.25	0.22	0.19	0.16	0.14	0.13
42	0.57	0.45	0.37	0.33	0.28	0.23	0.21	0.19
50	0.96	0.75	0.65	0.57	0.47	0.41	0.36	0.32
	1.87	1.40	1.10	0.92	0.81	0.64	0.52	0.43
63	1.69	1.32	1.12	1.00	0.83	0.70	0.63	0.58
	3.32	2.94	1.99	1.65	1.44	1.14	0.93	0.77
70	2.66	2.08	1.79	1.59	1.30	1.12	0.93	0.77
	4.30	3.23	2.59	2.16	1.86	1.47	1.21	1.00
80	6.33	4.72	3.63	3.02	2.69	2.05	1.67	1.38
100	10.26	7.64	6.04	4.94	4.31	3.36	2.70	2.20

Sizing

1. Conditions

(1) Motion profile

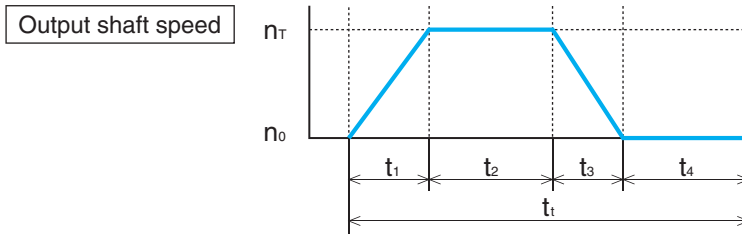

- n_T : Maximum output shaft speed (r/min)
- t_1 : Acceleration time (s)
- t_2 : Constant speed time (s)
- t_3 : Deceleration time (s)
- t_4 : Stopped time (s)
- t : Time for 1 cycle (s)

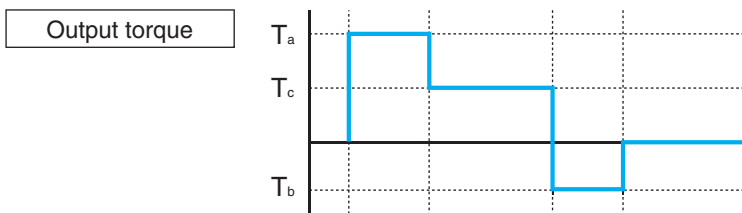

- T_a : Acceleration torque (N•m)
- T_c : Constant speed torque (N•m)
- T_b : Deceleration torque (N•m)

(2) Load moment of inertia I_r

Use the tables on page 13 to calculate I_r , the load moment of inertia on the output shaft of the reducer.

I_r : Load moment of inertia on the output shaft of the reducer ($\text{kg}\cdot\text{m}^2$)

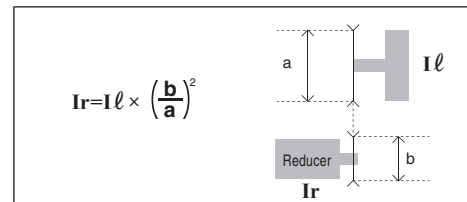

$$I_r = I \ell \times \left(\frac{b}{a}\right)^2$$

(3) Acceleration torque T_a and deceleration torque T_b

Acceleration torque $T_a = \Delta T_a + T_c$

$$\Delta T_a = \frac{2\pi I_r \times \Delta n_a}{60 \times t_1}$$

Deceleration torque $T_b = \Delta T_b - T_c$

$$\Delta T_b = \frac{2\pi I_r \times \Delta n_b}{60 \times t_3}$$

I_r : Load moment of inertia on the output shaft of the reducer ($\text{kg}\cdot\text{m}^2$)

ΔT_a : Inertia acceleration torque (N•m)

Δn_a : Speed difference (r/min) $\Delta n_a = n_T - n_0$

ΔT_b : Inertia deceleration torque (N•m)

Δn_b : Speed difference (r/min) $\Delta n_b = n_T - n_0$

(4) Constant speed torque T_c

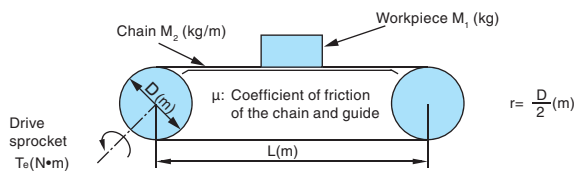

$$T_c = \underline{G} (M_1 + 1.1 \times M_2 \times L) \times \mu \times r$$

\underline{G} = Gravitational acceleration: 9.80665 m/s^2

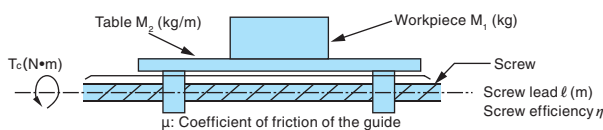

$$T_c = \frac{\underline{G} (M_1 + M_2) \times \mu \times \ell}{2 \times \pi \times \eta}$$

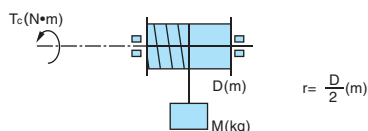

$$T_c = \underline{G} M \times r$$

2. Sizing procedure

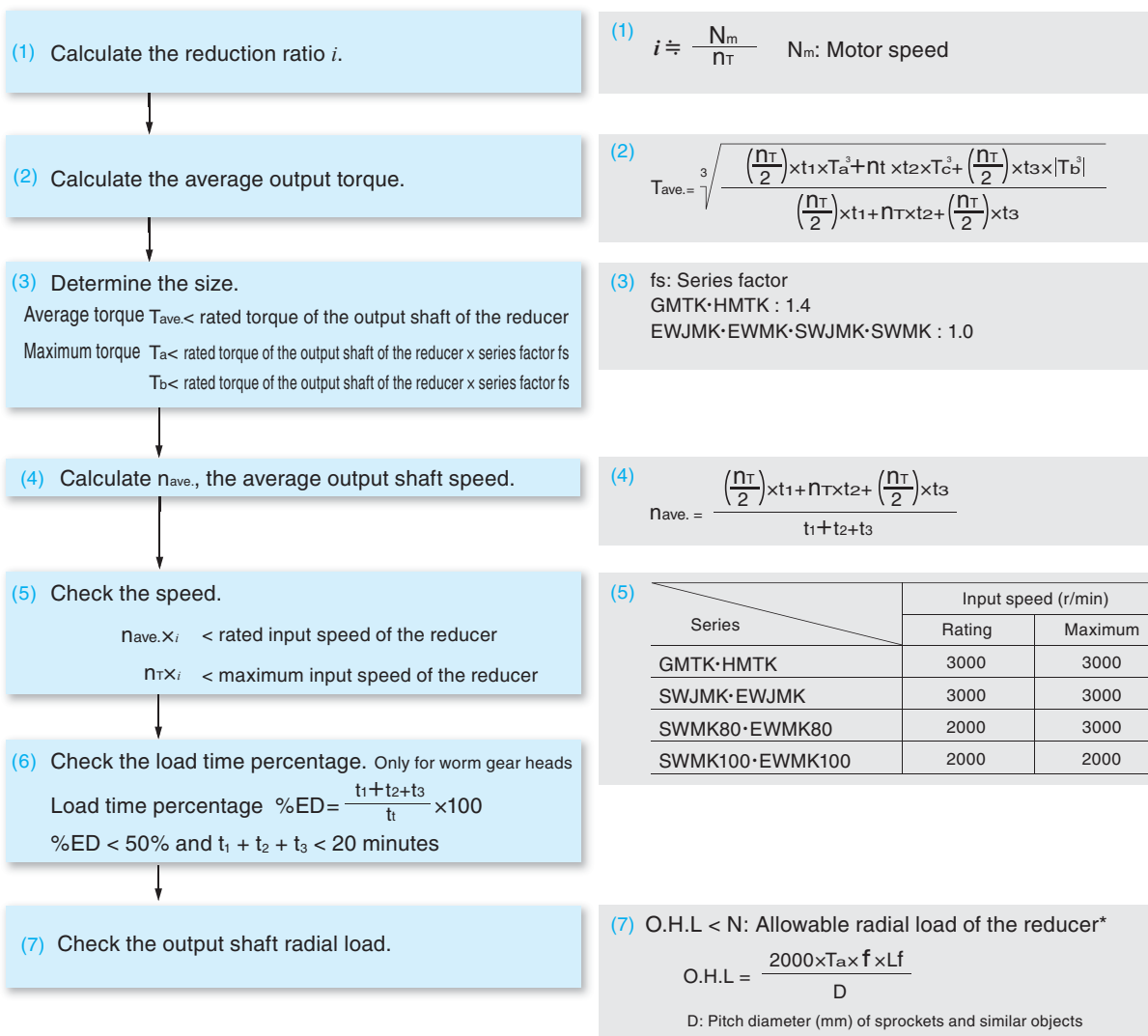

* See the allowable radial loads in the capacity tables.

f: O.H.L. factor

Chain	Gear toothed belt	V belt
1.0	1.25	1.5

Lf: Point of action factor

ℓ/Q	0.25	0.38	0.5	0.75	1
Lf	0.8	0.9	1	1.5	2

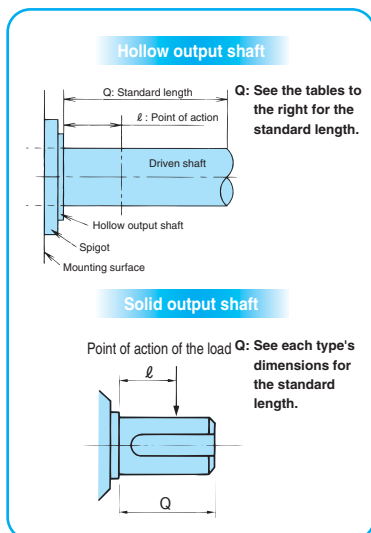

Standard length: Q For hollow output shafts

HMTK

Model no.	Reduction ratio	Q
HMTK0220H	5 to 60	36
HMTK0230H	80 to 200	42
HMTK0430H	5 to 50	
HMTK0435H	60 to 200	58
HMTK0735H	5 to 50	
HMTK0745H	60 to 200	66
HMTK1545H	5 to 80	
HMTK2245H	5 to 60	82
HMTK1555H	100 to 200	
HMTK2255H	80 to 120	

SWJMK SWMK

Model no.	Reduction ratio	Q
SWJMK35	10 to 60	20
SWJMK42	10 to 60	25
SWJMK50	10 to 60	30
SWJMK63	10 to 60	35
SWJMK70	10 to 60	40
SWMK80	10 to 60	50
SWMK100	10 to 60	55

Motor Mount Codes (Hypoid and Helical Gear Heads)

The dimensions corresponding to the servo motors of various companies are shown as mount codes. The product has been set with the capacities of each motor as standards, but be sure to use the product within the transfer capacity range of each gear head.

Note) The mount code interaction tables are representative examples that are current as of April 2019. It may be possible to support servo motors not shown in the tables, so contact us for details.

Note) The servo motor specifications may be changed depending on the situation of the motor manufacturer, so be sure to check the motor mounting dimensions and the mounting with our gear heads.

1. Mitsubishi Electric

J4 Series servo motors

Motor capacity	Rated speed	Model no.	Mount code	Hypoid gear head	Helical gear head
200 W	3000 r/min	HG-KR23	E4HC	HMTK02	⊙ GMTK02 ⊙
400 W		HG-KR43	E4HC	HMTK04	⊙ GMTK04 ⊙
750 W		HG-KR73	G5LC	HMTK07	⊙ GMTK07 ⊙
200 W	3000 r/min	HG-MR23	E4HC	HMTK02	⊙ GMTK02 ⊙
400 W		HG-MR43	E4HC	HMTK04	⊙ GMTK04 ⊙
750 W		HG-MR73	G5LC	HMTK07	⊙ GMTK07 ⊙
500 W	2000 r/min	HG-SR52	K3YC	HMTK07	⊙ GMTK07 ⊙
1000 W		HG-SR102	K3YC	HMTK15	⊙ GMTK15 ⊙
1500 W		HG-SR152	K3YC	HMTK15	⊙ GMTK15 ⊙
2000 W		HG-SR202	L1RC	HMTK22	⊙ GMTK22 ⊙
500 W	1000 r/min	HG-SR51	K3YC	HMTK15	⊙ GMTK15 ⊙
850 W		HG-SR81	K3YC	HMTK15	⊙ GMTK15 ⊙
1200 W		HG-SR121	L1RC	HMTK22	⊙ GMTK22 ⊙

J3 Series servo motors

Motor capacity	Rated speed	Model no.	Mount code	Hypoid gear head	Helical gear head
200 W	3000 r/min	HF-KP23	E4HC	HMTK02	⊙ GMTK02 ⊙
400 W		HF-KP43	E4HC	HMTK04	⊙ GMTK04 ⊙
750 W		HF-KP73	G5LC	HMTK07	⊙ GMTK07 ⊙
200 W	3000 r/min	HF-MP23	E4HC	HMTK02	⊙ GMTK02 ⊙
400 W		HF-MP43	E4HC	HMTK04	⊙ GMTK04 ⊙
750 W		HF-MP73	G5LC	HMTK07	⊙ GMTK07 ⊙
500 W	2000 r/min	HF-SP52	K3YC	HMTK07	⊙ GMTK07 ⊙
1000 W		HF-SP102	K3YC	HMTK15	⊙ GMTK15 ⊙
1500 W		HF-SP152	K3YC	HMTK15	⊙ GMTK15 ⊙
2000 W		HF-SP202	L1RC	HMTK22	⊙ GMTK22 ⊙
500 W	2000 r/min	HC-LP52	K3YC	HMTK07	⊙ GMTK07 ⊙
1000 W		HC-LP102	K3YC	HMTK15	⊙ GMTK15 ⊙
1500 W		HC-LP152	K3YC	HMTK15	⊙ GMTK15 ⊙
2000 W		HC-LP202	L1RC	HMTK22	⊙ GMTK22 ⊙

2. Yaskawa Electric

Σ -7 Series servo motors

Motor capacity	Rated speed	Model no.	Mount code	Hypoid gear head	Helical gear head
200 W	3000 r/min	SGM7A-02	E4HC	HMTK02	⊙ GMTK02 ⊙
400 W		SGM7A-04	E4HC	HMTK04	⊙ GMTK04 ⊙
750 W		SGM7A-08	G5LC	HMTK07	⊙ GMTK07 ⊙
1000 W		SGM7A-10	G5LC	HMTK15	△ GMTK15 △
850 W	1500 r/min	SGM7G-09	K3YC	HMTK07	⊙ GMTK07 ⊙
1300 W		SGM7G-13	K3YC	HMTK15	⊙ GMTK15 ⊙
200 W	3000 r/min	SGM7J-02	E4HC	HMTK02	⊙ GMTK02 ⊙
400 W		SGM7J-04	E4HC	HMTK04	⊙ GMTK04 ⊙
600 W		SGM7J-06	E4HC	HMTK07	⊙ GMTK07 ⊙
750 W		SGM7J-08	G5LC	HMTK07	⊙ GMTK07 ⊙
200 W	3000 r/min	SGM7P-02	G2HC	HMTK02	⊙ GMTK02 ⊙
400 W		SGM7P-04	G2HC	HMTK04	⊙ GMTK04 ⊙
750 W		SGM7P-08	K2LC	HMTK07	⊙ GMTK07 ⊙

Σ -V Series servo motors

Motor capacity	Rated speed	Model no.	Mount code	Hypoid gear head	Helical gear head
200 W	3000 r/min	SGMAV-02	E4HC	HMTK02	⊙ GMTK02 ⊙
400 W		SGMAV-04	E4HC	HMTK04	⊙ GMTK04 ⊙
200 W	3000 r/min	SGMJV-02	E4HC	HMTK02	⊙ GMTK02 ⊙
400 W		SGMJV-04	E4HC	HMTK04	⊙ GMTK04 ⊙

⊙ : Standard package

△ : Made to order

3. Fuji Electric FA Components & Systems

Motor capacity	Rated speed	Model no.	Mount code	Hypoid gear head	Helical gear head
200 W	3000 r/min	GYS201	E4HC	HMTK02	⊙ GMTK02 ⊙
375 W		GYS371	E4HC	HMTK04	⊙ GMTK04 ⊙
400 W		GYS401	E4HC	HMTK04	⊙ GMTK04 ⊙
750 W		GYS751	G5KC	HMTK07	⊙ GMTK07 ⊙
1000 W		GYS102	J4YC	HMTK15	△ GMTK15 △
1500 W		GYS152	J4YC	HMTK15	△ GMTK15 △
2000 W		GYS202	J4YC	HMTK22	△ GMTK22 △
200 W		3000 r/min	GYC201	G2HC	HMTK02
400 W	GYC401		G2HC	HMTK04	⊙ GMTK04 ⊙
750 W	GYC751		J2KC	HMTK07	△ GMTK07 △
1000 W	GYC102		K3YC	HMTK15	⊙ GMTK15 ⊙
1500 W	GYC152		K3YC	HMTK15	⊙ GMTK15 ⊙
2000 W	GYC202		K3YC	HMTK22	△ GMTK22 △
500 W	2000 r/min	GYG501C	K3LC	HMTK07	△ GMTK07 △
750 W		GYG751C	K3LC	HMTK07	△ GMTK07 △
1000 W		GYG102C	K3MC	HMTK15	⊙ GMTK15 ⊙
1500 W		GYG152C	K3MC	HMTK15	⊙ GMTK15 ⊙
2000 W	GYG202C	K3MC	HMTK22	△ GMTK22 △	
500 W	1500 r/min	GYG501B	K3LC	HMTK07	△ GMTK07 △
850 W		GYG851B	K3LC	HMTK15	⊙ GMTK15 ⊙
1300 W		GYG132B	K3LC	HMTK15	⊙ GMTK15 ⊙

5. Tamagawa Seiki

TBL-i II Series servo motors

Motor capacity	Rated speed	Model no.	Mount code	Hypoid gear head	Helical gear head
200 W	3000 r/min	TS4607	E4HC	HMTK02	⊙ GMTK02 ⊙
400 W		TS4609	E4HC	HMTK04	⊙ GMTK04 ⊙
200 W	3000 r/min	TS4611	G2HC	HMTK02	⊙ GMTK02 ⊙
400 W		TS4612	G2HC	HMTK04	⊙ GMTK04 ⊙
600 W		TS4613	G5LC	HMTK07	⊙ GMTK07 ⊙
750 W		TS4614	G5LC	HMTK07	⊙ GMTK07 ⊙

* TBL-i II is a registered trademark of Tamagawa Seiki Co., Ltd.

4. Panasonic

MINAS A5 Series servo motors

Motor capacity	Rated speed	Model no.	Mount code	Hypoid gear head	Helical gear head
200 W	3000 r/min	MSMD02	E3GC	HMTK02	△ GMTK02 △
400 W		MSMD04	E3HC	HMTK04	△ GMTK04 △
750 W		MSMD08	G4LC	HMTK07	△ GMTK07 △
400 W	3000 r/min	MSME04	E3HC	HMTK04	△ GMTK04 △
750 W		MSME08	G4LC	HMTK07	△ GMTK07 △
1000 W	3000 r/min	MSME10	J5LC	HMTK15	△ GMTK15 △
1500 W		MSME15	J5LC	HMTK15	△ GMTK15 △
2000 W		MSME20	J5LC	HMTK22	△ GMTK22 △
2000 W		MSME20	J5LC	HMTK22	△ GMTK22 △

* MINAS is a registered trademark of Panasonic Corporation.

6. Keyence

Motor capacity	Rated speed	Model no.	Mount code	Hypoid gear head	Helical gear head
200 W	3000 r/min	MV-M020	E4HC	HMTK02	⊙ GMTK02 ⊙
400 W		MV-M040	E4HC	HMTK04	⊙ GMTK04 ⊙
200 W	3000 r/min	SV-M020	E4HC	HMTK02	⊙ GMTK02 ⊙
400 W		SV-M040	E4HC	HMTK04	⊙ GMTK04 ⊙
750 W		SV-M075	G5LC	HMTK07	⊙ GMTK07 ⊙
200 W	3000 r/min	SV-B020	E4HC	HMTK02	⊙ GMTK02 ⊙
400 W		SV-B040	E4HC	HMTK04	⊙ GMTK04 ⊙
750 W		SV-B075	G5LC	HMTK07	⊙ GMTK07 ⊙

⊙ : Standard package

△ : Made to order

Motor Mount Codes (Worm Gear Heads)

The dimensions corresponding to the servo motors of various companies are shown as mount codes. Check the mount code corresponding to the servo motor being used, and then select a gear head whose size and reduction ratio match the operating conditions according to the information found under "Standard Mount Codes Categorized by Worm Gear Heads" and "Transfer Capacity Table" for each series.

Be sure to select a model within the performance range of each gear head corresponding to the load conditions.

Note) The mount code interaction tables are representative examples that are current as of April 2019. It may be possible to support servo motors not shown in the tables, so contact us for details.

Note) The servo motor specifications may be changed depending on the situation of the motor manufacturer, so be sure to check the motor mounting dimensions and the mounting with our gear heads.

Standard Mount Codes Categorized by Worm Gear Heads

Flange	Mount code	SWJMK/SWMK type						EWJMK/EWMK type							
		SWJMK35	SWJMK42	SWJMK50	SWJMK63	SWJMK70	SWMK80	SWMK100	EWJMK35	EWJMK42	EWJMK50	EWJMK63	EWJMK70	EWMK80	EWMK100
□ 60	E4DC	○	○	-	-	-	-	-	○	○	-	-	-	-	-
	E4HC	○	○	-	-	-	-	-	○	○	-	-	-	-	-
□ 80	G2HC	-	-	○	○	○	-	-	-	-	○	-	-	-	-
	G5LC	-	-	○	○	○	-	-	-	-	○	○	-	-	-
□ 130	K2LC	-	-	-	○	○	○	-	-	-	-	○	○	○	-
	K3YC	-	-	-	○	○	○	-	-	-	-	○	○	○	-
	K4PC	-	-	-	△	△	△	-	-	-	-	△	△	△	-
□ 176	L1MC	-	-	-	○	○	○	○	-	-	-	○	○	○	○
	L1PC	-	-	-	○	○	○	○	-	-	-	○	○	○	○
	L1RC	-	-	-	○	○	○	○	-	-	-	○	○	○	○

○: Standard package △: Made to order

Mount Code Tables Categorized by Motor Manufacturer

1. Mitsubishi Electric

J4 Series servo motors

Motor capacity	Rated speed	Model no.	Mount code
200 W	3000 r/min	HG-KR23	E4HC
400 W		HG-KR43	E4HC
750 W		HG-KR73	G5LC
200 W	3000 r/min	HG-MR23	E4HC
400 W		HG-MR43	E4HC
750 W		HG-MR73	G5LC
500 W	2000 r/min	HG-SR52	K3YC
1000 W		HG-SR102	K3YC
1500 W		HG-SR152	K3YC
2000 W		HG-SR202	L1RC
500 W	1000 r/min	HG-SR51	K3YC
850 W		HG-SR81	K3YC
1200 W		HG-SR121	L1RC
2000 W		HG-SR201	L1RC
3500 W	2000 r/min	HG-SR352	L1RC
5000 W		HG-SR502	L1RC
7000 W		HG-SR702	L1RC
3000 W	1000 r/min	HG-SR301	L1RC
4200 W		HG-SR401	L1RC

J3 Series servo motors

Motor capacity	Rated speed	Model no.	Mount code
200 W	3000 r/min	HF-KP23	E4HC
400 W		HF-KP43	E4HC
750 W		HF-KP73	G5LC
200 W	3000 r/min	HF-MP23	E4HC
400 W		HF-MP43	E4HC
750 W		HF-MP73	G5LC
500 W	2000 r/min	HF-SP52	K3YC
1000 W		HF-SP102	K3YC
1500 W		HF-SP152	K3YC
2000 W		HF-SP202	L1RC
500 W	2000 r/min	HC-LP52	K3YC
1000 W		HC-LP102	K3YC
1500 W		HC-LP152	K3YC
2000 W		HC-LP202	L1RC

2. Yaskawa Electric Σ -7 Series servo motors

Motor capacity	Rated speed	Model no.	Mount code
200 W	3000 r/min	SGM7A-02	E4HC
400 W		SGM7A-04	E4HC
600 W		SGM7A-06	E4HC
750 W		SGM7A-08	G5LC
1000 W		SGM7A-10	G5LC
1500 W		SGM7A-15	J3YC
2000 W		SGM7A-20	J3YC
300 W	1500 r/min	SGM7G-03	H2KC
450 W		SGM7G-05	H2KC
850 W		SGM7G-09	K3YC
1300 W		SGM7G-13	K3YC
1800 W		SGM7G-20	K3YC
200 W	3000 r/min	SGM7J-02	E4HC
400 W		SGM7J-04	E4HC
600 W		SGM7J-06	E4HC
750 W		SGM7J-08	G5LC
200 W	3000 r/min	SGM7P-02	G2HC
400 W		SGM7P-04	G2HC
750 W		SGM7P-08	K2LC

Σ -V Series servo motors

Motor capacity	Rated speed	Model no.	Mount code
200 W	3000 r/min	SGMAV-02	E4HC
400 W		SGMAV-04	E4HC
200 W	3000 r/min	SGMJV-02	E4HC
400 W		SGMJV-04	E4HC

3. Fuji Electric FA Components & Systems

Motor capacity	Rated speed	Model no.	Mount code
200 W	3000 r/min	GYC201	G2HC
400 W		GYC401	G2HC
750 W		GYC751	J2KC
1000 W		GYC102	K3YC
1500 W		GYC152	K3YC
2000 W		GYC202	K3YC
200 W	3000 r/min	GYS201	E4HC
375 W		GYS371	E4HC
400 W		GYS401	E4HC
750 W		GYS751	G5KC
500 W	1500 r/min	GYA501	K3YC
1500 W		GYA152	K4PC

4. Panasonic MINAS A5 Series servo motors

Motor capacity	Rated speed	Model no.	Mount code
200 W	3000 r/min	MSMD02	E3GC
400 W		MSMD04	E3HC
750 W		MSMD08	G4LC
400 W	3000 r/min	MSME04	E3HC
750 W		MSME08	G4LC
1000 W	2000 r/min	MDME10	J5LC
1500 W		MDME15	J5LC
2000 W		MDME20	J5LC

5. Tamagawa Seiki TBL-i II Series servo motors

Motor capacity	Rated speed	Model no.	Mount code
200 W	3000 r/min	TS4607	E4HC
400 W		TS4609	E4HC
200 W	3000 r/min	TS4611	G2HC
400 W		TS4612	G2HC
600 W		TS4613	G5LC
750 W		TS4614	G5LC

6. Keyence

Motor capacity	Rated speed	Model no.	Mount code
200 W	3000 r/min	MV-M020	E4HC
400 W		MV-M040	E4HC
200 W	3000 r/min	SV-M020	E4HC
400 W		SV-M040	E4HC
750 W		SV-M075	G5LC
200 W	3000 r/min	SV-B020	E4HC
400 W		SV-B040	E4HC
750 W		SV-B075	G5LC

Determining the moment of inertia

1. Moment of inertia of the rotating body

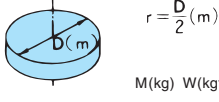
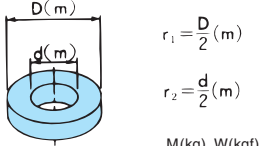
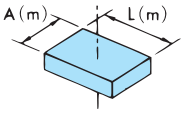
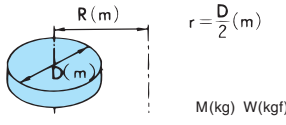
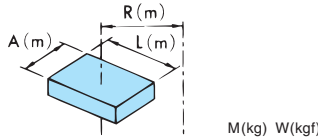
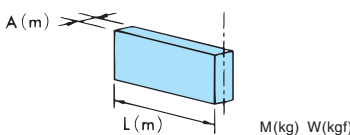
	Moving body	Moment of inertia calculation SI units	GD ² calculation (gravitational units)
When the center of movement is the shaft	 <p>$r = \frac{D}{2} (m)$ M(kg) W(kgf)</p>	$I = \frac{1}{2} Mr^2$ <p>(kg•m²)</p>	$GD^2 = \frac{1}{2} WD^2$ <p>(kgf•m²)</p>
	 <p>$r_1 = \frac{D}{2} (m)$ $r_2 = \frac{d}{2} (m)$ M(kg) W(kgf)</p>	$I = \frac{1}{2} M (r_1^2 + r_2^2)$ <p>(kg•m²)</p>	$GD^2 = \frac{1}{2} W (D^2 + d^2)$ <p>(kgf•m²)</p>
	 <p>M(kg) W(kgf)</p>	$I = \frac{1}{12} M (A^2 + L^2)$ <p>(kg•m²)</p>	$GD^2 = \frac{1}{3} W (A^2 + L^2)$ <p>(kgf•m²)</p>
When the center of movement is not the shaft	 <p>$r = \frac{D}{2} (m)$ M(kg) W(kgf)</p>	$I = M \left(\frac{r^2}{2} + R^2 \right)$ <p>(kg•m²)</p>	$GD^2 = W \left(\frac{1}{2} D^2 + 4R^2 \right)$ <p>(kgf•m²)</p>
	 <p>M(kg) W(kgf)</p>	$I = \frac{M}{4} \left(\frac{A^2 + L^2}{3} + 4R^2 \right)$ <p>(kg•m²)</p>	$GD^2 = W \left(\frac{A^2 + L^2}{3} + 4R^2 \right)$ <p>(kgf•m²)</p>
	 <p>M(kg) W(kgf)</p>	$I = \frac{M}{12} (A^2 + 4L^2)$ <p>(kg•m²)</p>	$GD^2 = \frac{1}{3} W (A^2 + 4L^2)$ <p>(kgf•m²)</p>

2. Equivalent moment of inertia of a body moving in parallel

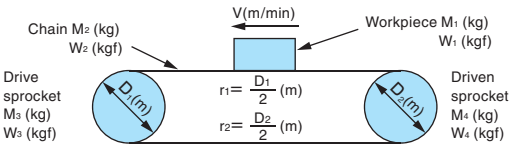
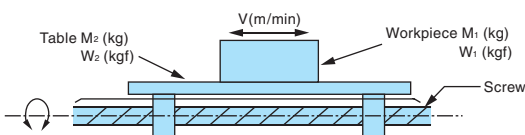
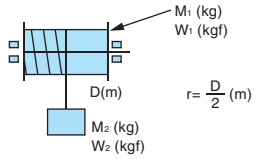
 <p>Chain M₂ (kg) W₂ (kgf) Drive sprocket M₃ (kg) W₃ (kgf) Workpiece M₁ (kg) W₁ (kgf) Driven sprocket M₄ (kg) W₄ (kgf) $r_1 = \frac{D_1}{2} (m)$ $r_2 = \frac{D_2}{2} (m)$ V(m/min)</p>	$I = M_1 r_1^2 + M_2 r_1^2 + \frac{M_3 r_1^2 + M_4 r_2^2}{2}$ <p>(kg•m²)</p>	$GD^2 = W_1 D_1^2 + W_2 D_1^2 + \frac{W_3 D_1^2 + W_4 D_2^2}{2}$ <p>(kgf•m²)</p>
 <p>Table M₂ (kg) W₂ (kgf) Workpiece M₁ (kg) W₁ (kgf) Screw V(m/min)</p>	$I = \frac{1}{4} (M_1 + M_2) \times \left(\frac{V}{\pi n} \right)^2$ <p>(kg•m²)</p> <p>n: Motor speed (r/min) in relation to V</p>	$GD^2 = (W_1 + W_2) \times \left(\frac{V}{\pi n} \right)^2$ <p>(kgf•m²)</p> <p>n: Number of motor rotations in relation to V (r/min)</p>
 <p>M₁ (kg) W₁ (kgf) D(m) M₂ (kg) W₂ (kgf) $r = \frac{D}{2} (m)$ V(m/min)</p>	$I = \frac{1}{2} M_1 r^2 + M_2 r^2$ <p>(kg•m²)</p>	$GD^2 = \frac{1}{2} W_1 D^2 + W_2 D^2$ <p>(kgf•m²)</p>

TERVO

Hypoid Gear Head HMTK Type

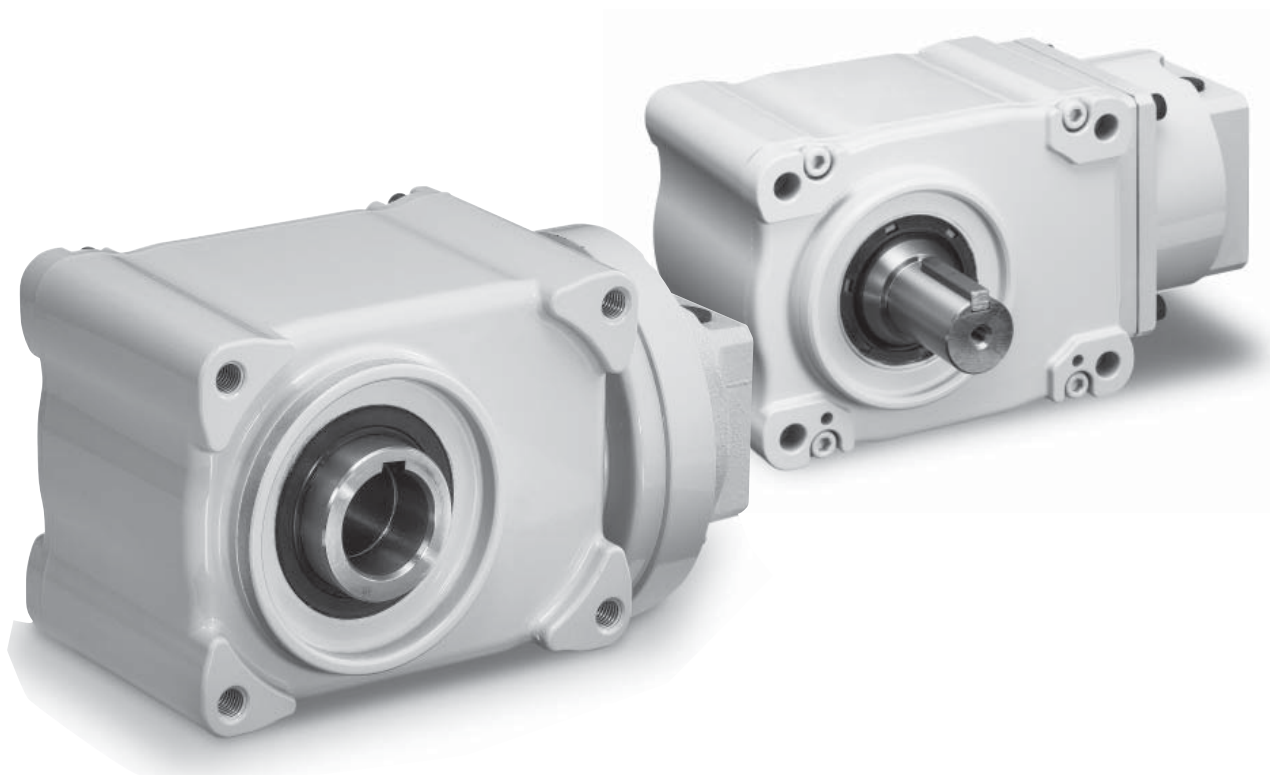

Contents

Models	Page 15
Capacity Table	Page 15
Dimensions.....	Page 16
Motor Mount Dimensions.....	Page 17

Models

Hollow output shaft

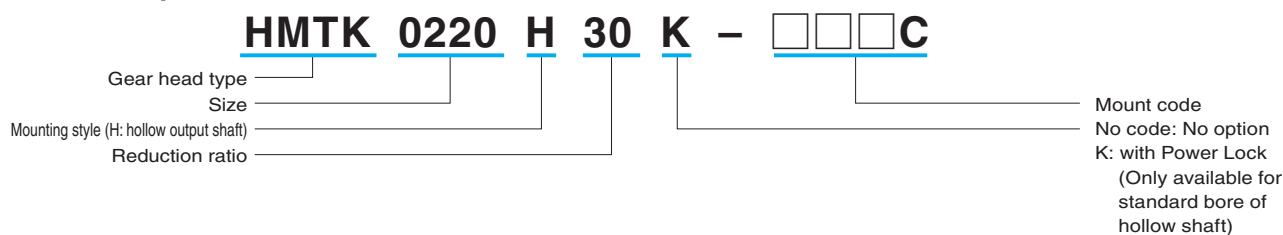

Solid output shaft

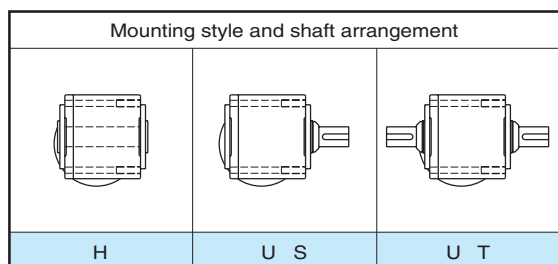
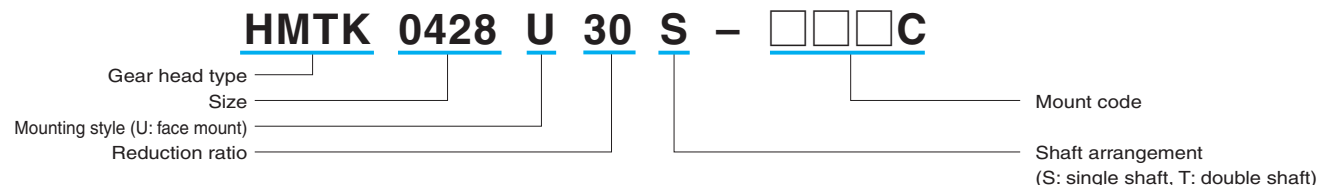

[Mounting style]

- H : Hollow shaft
- U S : Face mount, single output shaft
- U T : Face mount, double output shaft
- L : Foot mount (contact us)

[Output shaft rotating direction]

- As seen from the surface of the through-hole side with rotations made to the right when facing the input shaft
- 2-stage: Rotations to the left
- 3-stage: Rotations to the right

Capacity Table

Size	Reduction ratio	Reduction stages	Rated input	Rated torque of the output shaft N·m			Allowable radial load on output shaft N
				Input speed r/min			
				3000	2000	1500	
HMTK0220H HMTK0222U	5	2	0.2 kW	2.8	4.2	5.6	588
	10			5.4	8.1	10.8	980
	15			8.4	12.5	16.7	1078
	20			11.3	16.9	22.5	1176
	25	3		13.7	20.6	27.4	1274
	30			15.7	23.6	31.4	1421
	40			21.1	31.6	42.1	1617
	50			26.5	39.7	52.9	1862
HMTK0230H HMTK0228U	60	3	31.9	47.8	63.7	2009	
	80		42.2	63.2	84.3	2254	
	100		53.0	79.5	106	2548	
	120		63.0	94.5	126	2793	
	160		84.5	127	169	3332	
	200		84.5	127	169	3332	
HMTK0430H HMTK0428U	5	2	0.4 kW	5.4	8.1	10.8	931
	10			11.3	16.9	22.5	1568
	15			16.7	25.0	33.3	1715
	20			22.1	33.1	44.1	1862
	25	3		28.0	41.9	55.9	2009
	30			33.3	50.0	66.6	2205
	40			42.2	63.2	84.3	2450
	50			53.0	79.5	106	2793
HMTK0435H HMTK0438U	60	3	63.0	94.5	126	3038	
	80		84.5	127	169	3479	
	100		106	159	212	3920	
	120		127	191	254	4410	
	160		169	254	338	4410	
	200		187	281	374	4410	
HMTK0735H HMTK0738U	5	2	0.75 kW	10.3	15.5	20.6	1519
	10			21.1	31.6	42.1	2205
	15			31.4	47.0	62.7	2401
	20			41.7	62.5	83.3	2646
	25	3		52.0	78.0	104	2891
	30			62.5	93.8	125	3136
	40			79.5	119	159	3626
	50			99.0	149	198	4116
HMTK0745H HMTK0742U	60	3	119	178	238	4508	
	80		159	238	317	5390	
	100		198	297	396	6272	
	120		238	356	475	6272	
	160		311	466	621	6272	
	200		311	466	621	6272	

Size	Reduction ratio	Reduction stages	Rated input	Rated torque of the output shaft N·m			Allowable radial load on output shaft N
				Input speed r/min			
				3000	2000	1500	
HMTK1545H HMTK1542U	5	2	1.5 kW	20.6	30.9	41.2	2058
	10			41.7	62.5	83.3	2842
	15			62.0	93	124	3234
	20			83	125	166	3626
	25	3		104	156	208	4018
	30			125	187	249	4508
	40			159	238	317	5292
	50			198	297	396	6076
HMTK1555H HMTK1550U	60	3	238	356	475	6272	
	80		317	476	634	6272	
	100		396	594	792	9800	
	120		476	713	951	9800	
	160		588	882	1176	9800	
	200		588	882	1176	9800	
HMTK2245H HMTK2242U	5	2	2.2 kW	30.4	45.6	60.8	3038
	10			60.8	91.5	122	3822
	15			91	137	182	4214
	20			122	183	244	4606
	25	3		145	218	290	4998
	30			174	262	349	5390
	40			232	349	465	5782
	50			290	436	581	6076
HMTK2255H HMTK2250U	60	3	348	523	697	6272	
	80		465	698	930	9800	
	100		534	801	1068	9800	
	120		588	882	1176	9800	

- (1) Reduction ratios other than that shown below are actual reduction ratios. For the 2245H- and 2242U-size reducers, the actual reduction ratio of 1/50 will be 7/345.
- (2) Contact us for details on rated inputs that are less than the input speed 1500 r/min.
- (3) For details on the moment of inertia on input shaft and backlash, see pages 29 and 30.

Maximum input speed

Size	HMTK02 to 22
r/min	3000

Dimensions

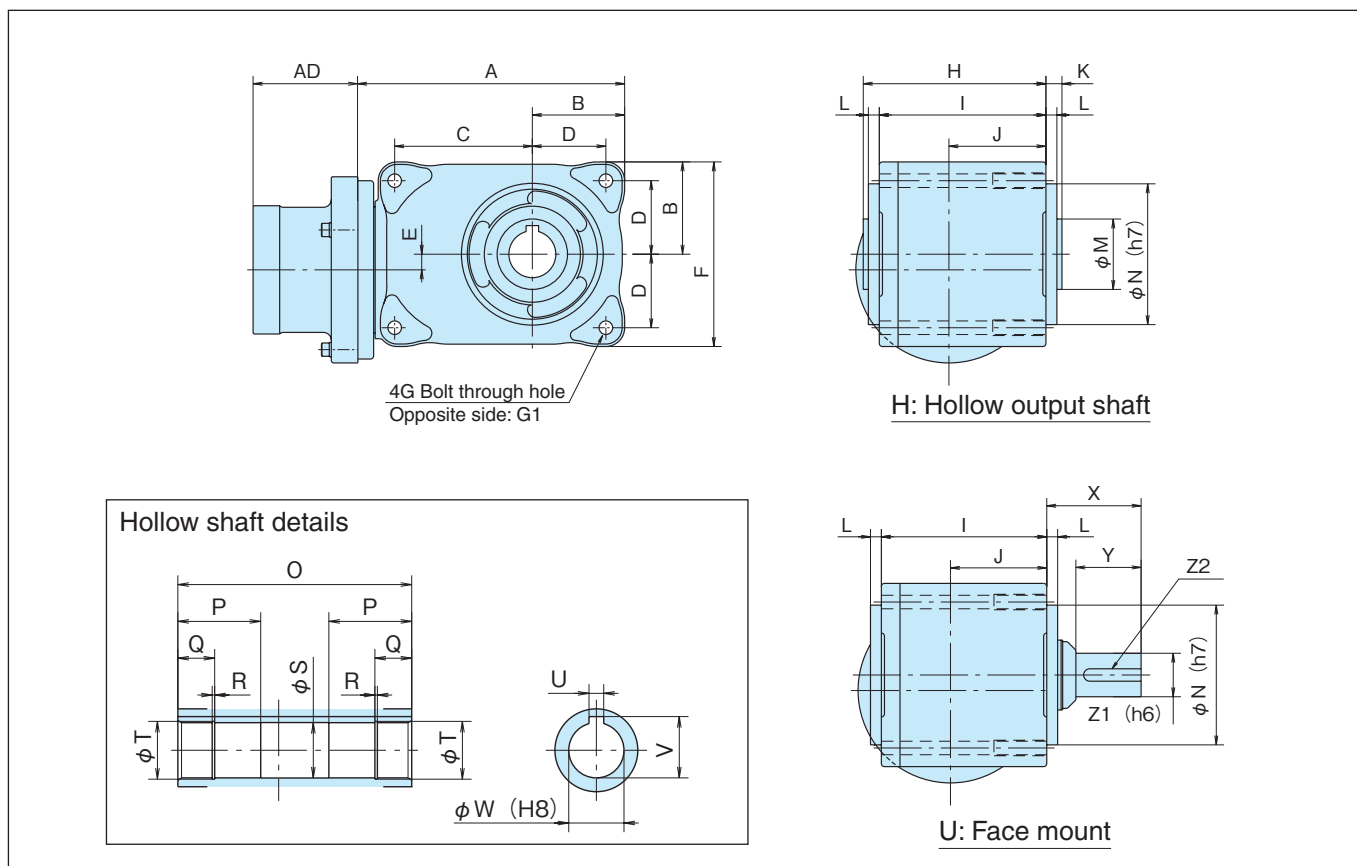

Unit: mm

Size	Reduction ratio	A	B	C	D	E	F	G	G1	H	I	J	K	L
0220H/0222U	5~60	143	48	70	38	2	96	M6	M8-38L	93	85	62	8	6
0230H/0228U	80~200	166	59	88	47	10	118	M8	M10-34L	116.7	106.5	62	10.3	7
0430H/0428U	5~50	170.5	59	88	47	10	118	M8	M10-34L	116.7	106.5	62	10.3	7
0435H/0438U	60~200	200.5	70	106	58	12	140	M10	M12-46L	143	133	75	10	7
0735H/0738U	5~50	200	70	106	58	12	140	M10	M12-46L	143	133	75	10	7
0745H/0742U	60~200	237	89	123	73	16	178	M12	M16-44L	159.7	149.5	84.5	10.3	7
1545H/1542U	5~80	254.5	89	123	73	16	178	M12	M16-44L	159.7	149.5	84.5	10.3	7
1555H/1550U	100~200	368.5	130	182	105	23	260	M16	M20-52L	190	176	104	14	10
2245H/2242U	5~60	254.5	89	123	73	16	178	M12	M16-44L	159.7	149.5	84.5	10.3	7
2255H/2250U	80~100	368.5	130	182	105	23	260	M16	M20-52L	190	176	104	14	10

Size	Reduction ratio	M	N	O	P	Q	R	S	T	U	V	W	X	Y	Z1	Z2
0220H/0222U	5~60	32	70	101	36	15	1.15	20.1	21	6	22.8	20	44	36	22	6x6-32L
0230H/0228U	80~200	45	90	127	45	20	1.35	30.1	31.4	8	33.3	30	61	42	28	8x7-37L
0430H/0428U	5~50	45	90	127	45	20	1.35	30.1	31.4	8	33.3	30	61	42	28	8x7-37L
0435H/0438U	60~200	50	90	153	52	23	1.65	35.1	37.0	10	38.3	35	73.5	58	38	10x9-50L
0735H/0738U	5~50	50	90	153	52	23	1.65	35.1	37.0	10	38.3	35	73.5	58	38	10x9-50L
0745H/0742U	60~200	60	90	170	67	30	1.90	45.1	47.5	14	48.8	45	85	66	42	12x8-60L
1545H/1542U	5~80	60	90	170	67	30	1.90	45.1	47.5	14	48.8	45	85	66	42	12x8-60L
1555H/1550U	100~200	75	140	204	82	37	2.20	55.1	58.0	16	59.3	55	107	82	50	14x9-75L
2245H/2242U	5~60	60	90	170	67	30	1.90	45.1	47.5	14	48.8	45	85	66	42	12x8-60L
2255H/2250U	80~100	75	140	204	82	37	2.20	55.1	58.0	16	59.3	55	107	82	50	14x9-75L

Note) Four tap holes are present on the mounting surface side of the case. The prepared tap holes are through holes.

Note) Mounting style L: The foot mount of solid output shafts is supported by attaching the L feet for the hypoid motor foot mount to mounting style U.

Contact us for details.

Motor Mount Dimensions

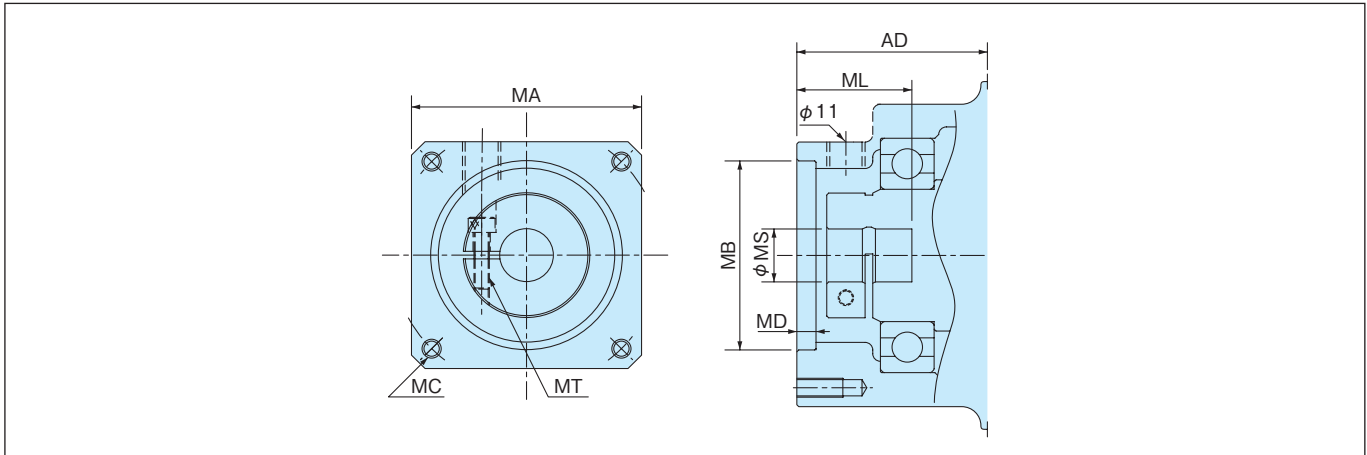

Unit: mm

Size	Mount code	Motor mount dimensions												
		AD	MA	MB	MC	MD	ML(min)	MS	MT					
HMTK0220H HMTK0222U	E4DC	50	□60	φ50G7	M5 12 deep (PCD70)	5	30(25)	φ8	M4					
	E4HC							φ14						
HMTK0230H HMTK0228U	E4DC	54	□60	φ50G7	M5 12 deep (PCD70)	5	30(25)	φ8	M4					
	E4EC							φ9						
	E4HC							φ14						
	G2HC							□80		φ70G7	M6 10 deep (PCD90)	5	30(25)	φ14
HMTK04	E4HC	54	□60	φ50G7	M5 12 deep (PCD70)	5	30(25)	φ14	M4					
	G2HC		□80	φ70G7	M6 10 deep (PCD90)	5	30(25)	φ14	M4					
HMTK07	G5KC	63	□80	φ70G7	M6 15 deep (PCD90)	5	40(30)	φ16	M5					
	G5LC							φ19						
	K2KC							□130		φ110G7	M8 13 deep (PCD145)	5	40(30)	φ16
	K2LC													φ19
K3YC	81	□130	φ110G7	M8 16 deep (PCD145)	8	58(40)	φ24	M5						
HMTK15	K3LC	77	□130	φ110G7	M8 16 deep (PCD145)	8	58(40)	φ19	M5					
	K3MC							φ22						
	K3YC							φ24						
HMTK22	L1PC	121	□180	φ114.3G7	M12 16 deep (PCD200)	8	80(55)	φ28	M6					
	L1RC							φ35						

Note) For details on the support of the servo motors of various companies, see pages 9 and 10.

Note) Contact us for details on servo motors that have dimensions other than those listed above.

For details, use the sizing inquiry form on page 38 to contact us.

TERVO

Helical Gear Head GMTK Type

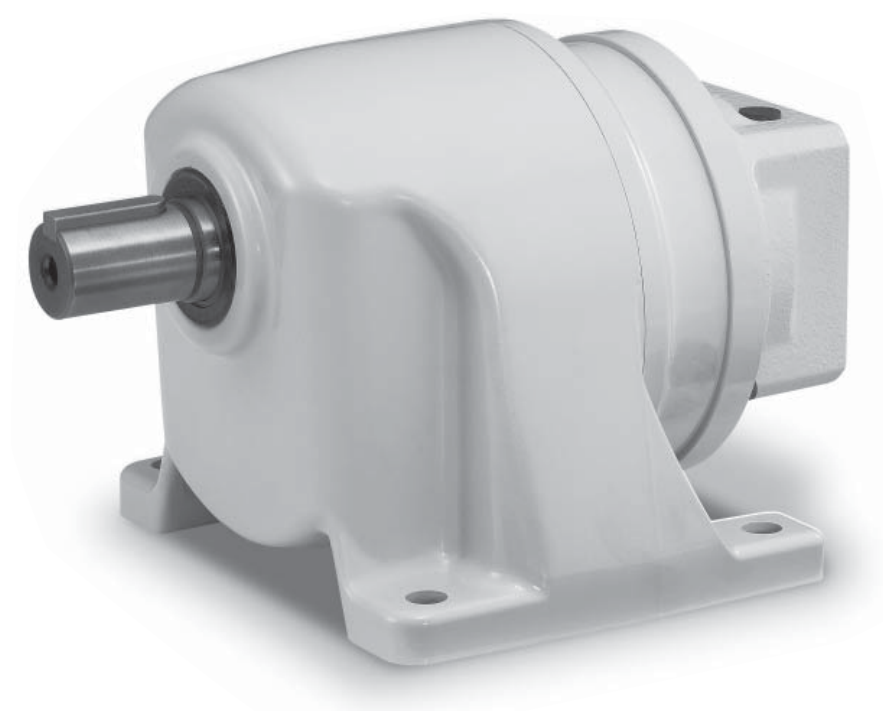

Contents

Models	Page 19
Capacity Table	Page 19
Dimensions.....	Page 20
Motor Mount Dimensions.....	Page 21

Models

Foot mount

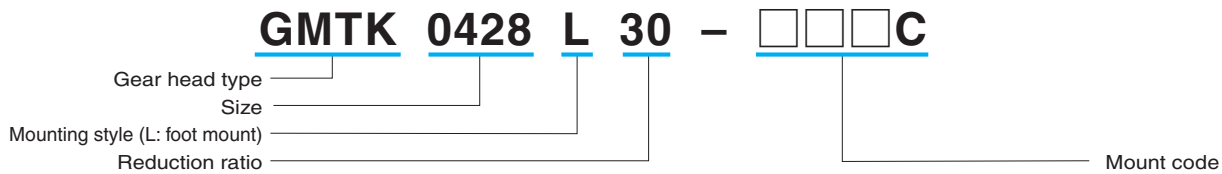

Face mount, flange installation

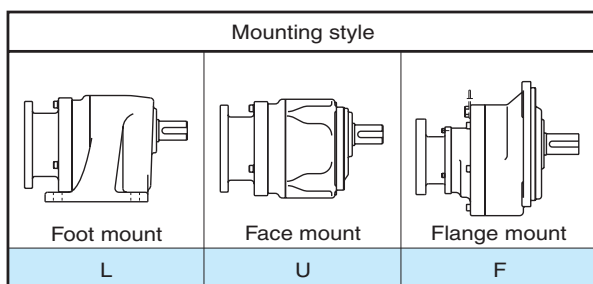
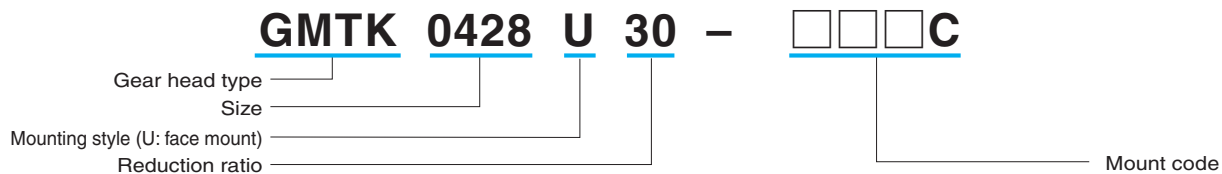

[Mounting style]

- L : Foot mount
- U : Face mount
- F : Flange mount

[Output shaft rotating direction]

- 2-stage: The same direction as the input
- 3-stage: The opposite direction to the input

Capacity Table

Size	Nominal reduction ratio (actual reduction ratio)	Reduction stages	Rated input	Rated torque of the output shaft N·m			Allowable radial load N
				Input speed r/min			
				3000	2000	1500	
GMTK 0218L/U	5 (287 / 1444)	2	0.2 kW	2.9	4.3	5.7	431
	10 (140 / 1369)			5.9	8.9	11.8	686
	15 (5 / 74)			8.8	13.2	17.6	902
	20 (28 / 555)			11.3	16.9	22.5	1098
	25 (70 / 1739)			14.2	21.3	28.4	1264
GMTK 0224L/U	30 (28 / 825)	3	0.4 kW	17.2	25.7	34.3	1431
	40 (33 / 1288)			23.1	34.6	46.1	1735
	50 (27 / 1334)			28.4	42.6	56.8	2009
	60 (12 / 713)			34.3	51.5	68.6	2274
	75 (7 / 506)			43.1	64.7	86.2	2636
GMTK 0228L/U	100 (200 / 19557)	3	0.75 kW	57.5	86.3	115	3195
	120 (170 / 20511)			68.5	103	137	3606
	165 (140 / 22419)			94.5	142	189	4459
	200 (40 / 7791)			109	164	218	4822
	5 (20 / 99)			2	0.4 kW	6.1	9.1
10 (16 / 165)	12.3	18.4	24.5			1098	
15 (24 / 363)	18.2	27.2	36.3			1431	
20 (80 / 1551)	24.0	36.0	48.0			1735	
25 (4 / 99)	30.4	45.6	60.8			2009	
GMTK 0428L/U	30 (8 / 247)	3	0.75 kW	36.3	54.4	72.5	2274
	40 (77 / 3120)			47.1	70.6	94.1	2754
	50 (11 / 560)			59.0	88.5	118	3195
	60 (1 / 60)			70.0	105	140	3606
	75 (77 / 5640)			87.5	131	175	4185
GMTK 0438L/U	100 (147 / 14927)	3	1.5 kW	117	176	234	5076
	120 (133 / 15576)			141	211	281	5733
	165 (105 / 16874)			182	273	364	6664
	200 (91 / 17523)			195	292	389	6684
	5 (49 / 248)			2	0.75 kW	11.3	17.0
10 (63 / 640)	22.6	33.8	45.1			1666	
15 (49 / 720)	33.8	50.7	67.6			2176	
20 (77 / 1536)	45.6	68.3	91.1			2636	
25 (63 / 1600)	57.0	85.5	114			3058	
GMTK 0738L/U	30 (21 / 638)	3	1.5 kW	68.0	102	136	3459
	40 (63 / 2560)			87.5	131	175	4185
	50 (7 / 344)			110	165	220	4861
	60 (147 / 8832)			132	198	264	5488
	75 (9 / 672)			150	225	300	5792

Size	Nominal reduction ratio (actual reduction ratio)	Reduction stages	Rated input	Rated torque of the output shaft N·m			Allowable radial load N
				Input speed r/min			
				3000	2000	1500	
GMTK 0742L/F	100 (57 / 5488)	3	0.75 kW	220	329	439	7301
	120 (2 / 245)			264	395	527	8242
	165 (39 / 6272)			362	543	724	9800
	200 (99 / 19600)			368	551	735	9800
GMTK 1538L/U	5 (1 / 5)	2	1.5 kW	22.7	34.0	45.3	1666
	10 (1 / 10)			45.6	68.3	91.1	2548
	20 (13 / 255)			90.5	136	181	4047
	25 (11 / 265)			113	170	226	4694
	30 (1 / 30)			136	204	272	5302
GMTK 1542L/F	40 (91 / 3572)	3	2.2 kW	176	263	351	6292
	60 (1547 / 95128)			264	395	527	8242
	75 (1365 / 99452)			330	494	659	9565
GMTK 2242L/F	5 (1 / 5)	2	2.2 kW	33.3	50.0	66.6	2078
	10 (77 / 760)			66.6	99.8	133	3293
	20 (91 / 1880)			133	200	266	5223
30 (7 / 204)			199	299	399	6850	

(1) Contact us for details on rated inputs that are less than or equal to the input speed 1500 r/min.

(2) For details on the moment of inertia on input shaft and backlash, see pages 29 and 30.

Note) Keyed/flatted servo motors that exceed the values listed above can also be available by the Gear Motor TA Series with an adapter.
 For details, use the sizing inquiry form on page 38 to contact us.

Maximum input speed

Size	GMTK02 to 22
r/min	3000

Dimensions, GMTK L Type

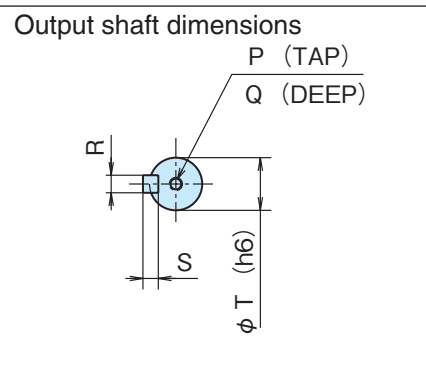
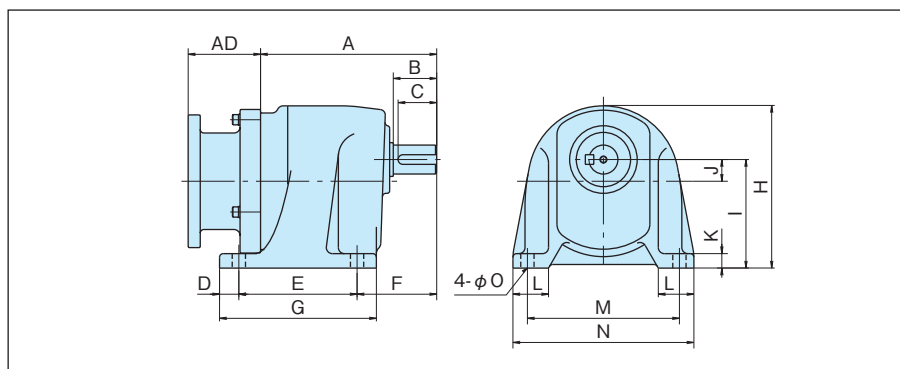

Unit: mm

Unit: mm

Size	Reduction ratio	A	B	C	D	E	F	G	H	I	J	K	L	M	N	O
0218L	5	126	28	25	16	98	57	130	135	90	18	12	30	126	150	11
	10~25	105	28	25	12	87	49	111	130	85	15	10	31	118	140	9
0224L	30~75	135	36	32	16	98	66	130	135	90	18	12	30	126	150	11
0228L	100~200	161	42	37	16	116	78	148	159	105	23	15	35	150	180	12
0424L	5~25	146	36	32	16	98	66	130	135	90	18	12	30	126	150	11
0428L	30~75	176	42	37	16	116	78	148	159	105	23	15	35	150	180	12
0438L	100~200	216	58	50	17	140	98	174	199	130	27	20	41	186	220	15
0728L	5~25	188	42	37	16	116	78	148	159	105	23	15	35	150	180	12
0738L	30~75	231	58	50	17	140	98	174	199	130	27	20	41	186	220	15
0742L	100~200	260	66	60	25	150	96	200	230	150	33	22	60	210	260	18
1538L	5~30	249	58	50	17	140	98	174	199	130	27	20	41	186	220	15
1542L	40~75	268	66	60	25	150	96	200	230	150	33	22	60	210	260	18
2242L	5~30	238	66	60	25	150	96	200	230	150	33	22	60	210	260	18

Size	Reduction ratio	P	Q	R	S	T
0218U/L	5	M6	16	6	6	18
	10~25	M6	16	6	6	18
0224U/L	30~75	M6	16	8	7	24
0228U/L	100~200	M8	20	8	7	28
0424U/L	5~25	M6	16	8	7	24
0428U/L	30~75	M8	20	8	7	28
0438U/L	100~200	M10	25	10	8	38
0728U/L	5~25	M8	20	8	7	28
0738U/L	30~75	M10	25	10	8	38
0742F/L	100~200	M10	25	12	8	42
1538U/L	5~30	M10	25	10	8	38
1542F/L	40~75	M10	25	12	8	42
2242F/L	5~30	M10	25	12	8	42

Dimensions, GMTK U (F) Type

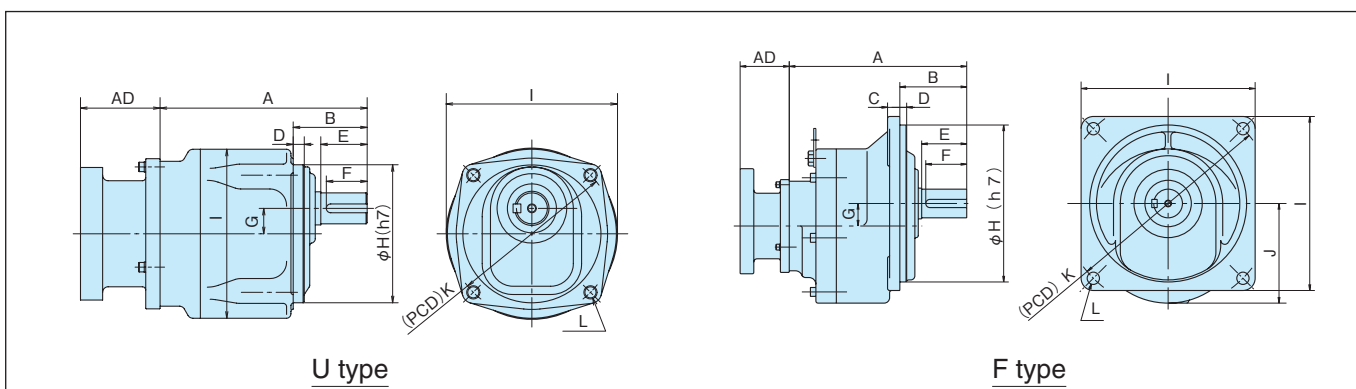

U type

F type

Unit: mm

Size	Reduction ratio	A	B	C	D	E	F	G	H	I	J	K	L
0218U	5	126	50	-	10	28	25	18	105	phi 128	-	130	4-M10-32L
	10~25	105	46	-	8	28	25	15	90	phi 109	-	110	4-M8-24L
0224U	30~75	135	59	-	10	36	32	18	105	phi 128	-	130	4-M10-32L
0228U	100~200	161	67	-	10	42	37	23	125	phi 157	-	150	4-M12-38L
0424U	5~25	146	59	-	10	36	32	18	105	phi 128	-	130	4-M10-32L
0428U	30~75	176	67	-	10	42	37	23	125	phi 157	-	150	4-M12-38L
0438U	100~200	216	87	-	12	58	50	27	155	phi 191	-	195	4-M16-34L
0728U	5~25	188	67	-	10	42	37	23	125	phi 157	-	150	4-M12-38L
0738U	30~75	231	87	-	12	58	50	27	155	phi 191	-	195	4-M16-34L
0742F	100~200	260	98	18	10	66	60	33	230	square 255	146	310	4-phi 18
1538U	5~30	249	87	-	12	58	50	27	155	phi 191	-	195	4-M16-34L
1542F	40~75	268	98	18	10	66	60	33	230	square 255	146	310	4-phi 18
2242F	5~30	238	98	18	10	66	60	33	230	square 255	146	310	4-phi 18

Motor Mount Dimensions

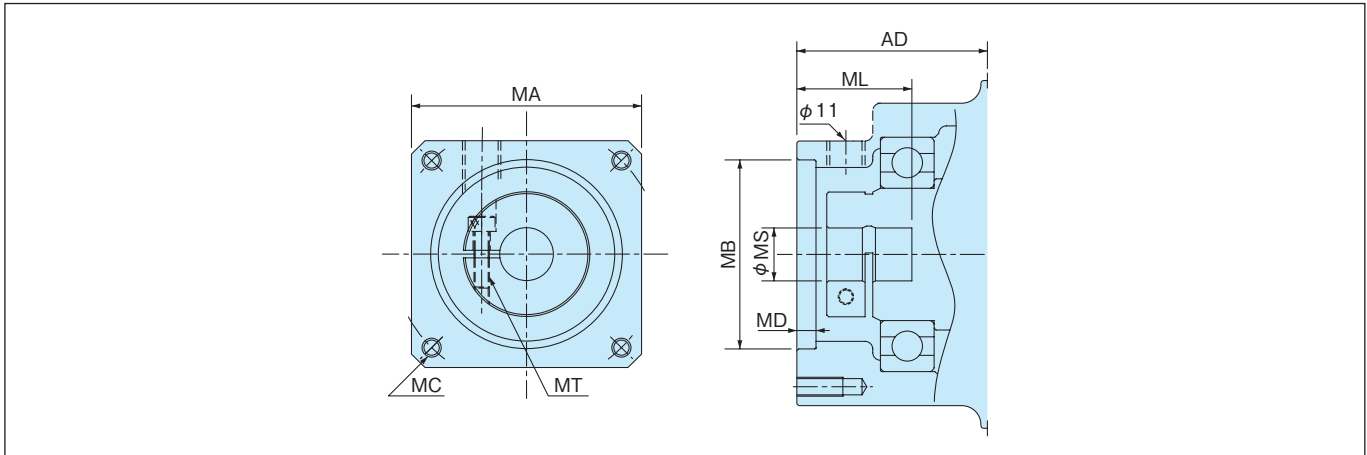

Unit: mm

Size	Mount code	Motor mount dimensions							
		AD	MA	MB	MC	MD	ML(min)	MS	MT
GMTK02	E4DC	65	□60	φ50G7	M5 12 deep (PCD70)	5	30(25)	φ8	M4
	E4EC							φ9	
	E4HC							φ14	
	G2HC							φ14	
GMTK04	E4HC	54	□60	φ50G7	M5 12 deep (PCD70)	5	30(25)	φ14	M4
	G2HC		□80	φ70G7	M6 10 deep (PCD90)	5	30(25)	φ14	M4
GMTK07	G5KC	63	□80	φ70G7	M6 15 deep (PCD90)	5	40(30)	φ16	M5
	G5LC							φ19	
	K2KC	81	□130	φ110G7	M8 13 deep (PCD145)	5	40(30)	φ16	M5
	K2LC							φ19	
	K3YC							φ24	
GMTK15	K3LC	77	□130	φ110G7	M8 16 deep (PCD145)	8	58(40)	φ19	M5
	K3MC							φ22	
	K3YC							φ24	
GMTK22	L1PC	121	□180	φ114.3G7	M12 16 deep (PCD200)	8	80(55)	φ28	M6
	L1RC							φ35	

Note) For details on the support of the servo motors of various companies, see pages 9 and 10.

Note) Contact us for details on servo motors that have dimensions other than those listed above.

For details, use the sizing inquiry form on page 38 to contact us.

TERVO

Worm Gear Head

SWJMK/SWMK Type EWJMK/EWMK Type

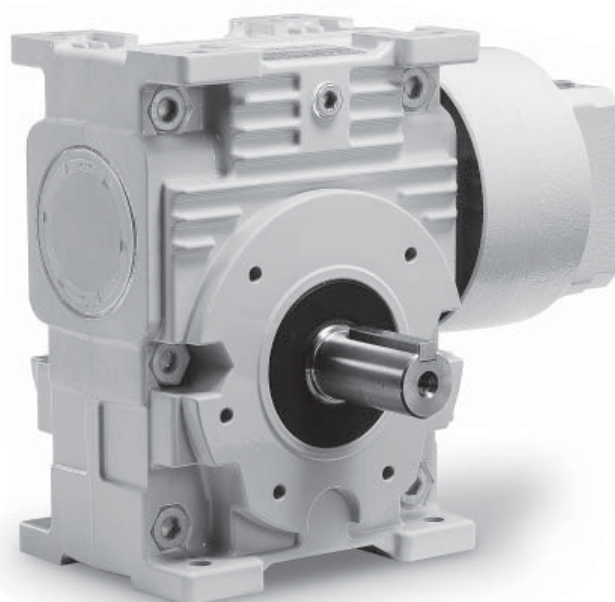
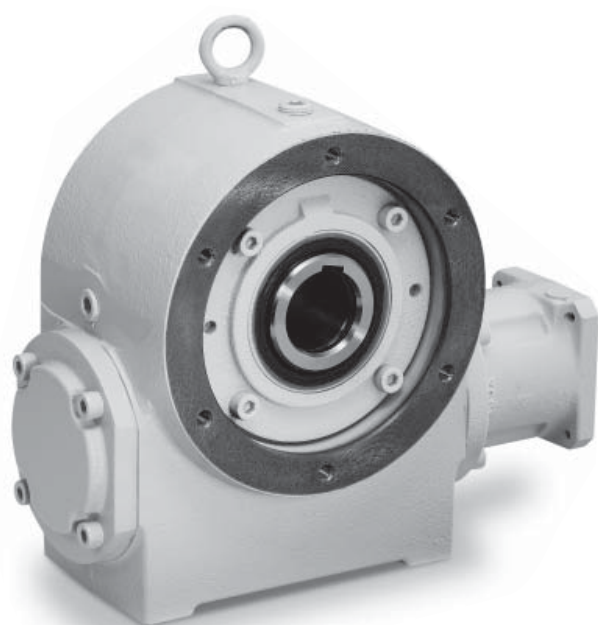

Worm Gear Head

Contents

SWJMK/SWMK Type

Models	Page 23
Capacity Table	Page 23
Dimensions	Page 24

EWJMK/EWMK Type

Models	Page 25
Capacity Table	Pages 25 and 26
Dimensions	Page 26

Models

Hollow output shaft

SWMK 80 T **30** **LF -** □ □ □ C

Gear head type	Size	Mounting position
SWJMK	35,42,50 63,70	E
SWMK	80,100	T B V

Reduction ratio
30 : 1/30

For the shaft arrangement, see the following table.

Mount code

Capacity Table

Size	Mounting position	Reduction ratio (actual reduction ratio)	Allowable torque on output shaft N·m			Allowable radial load N			Allowable axial load N			Allowable input kW		
			Input speed r/min			Input speed r/min			Input speed r/min			Input speed r/min		
			3000	2000	1500	3000	2000	1500	3000	2000	1500	3000	2000	1500
SWJMK35	E	10	12.2	15.7	19.2	1335	1504	1648	2457	2876	3249	0.44	0.38	0.35
		15	13.9	17.7	21.6	1545	1745	1917	3015	3544	4020	0.35	0.30	0.27
		20	14.5	18.4	22.3	1713	1939	2134	3478	4100	4141	0.28	0.25	0.23
		25	15.5	19.6	23.8	1853	2098	2310	3862	4141	4141	0.25	0.22	0.20
		30	15.4	19.4	23.5	1987	2253	2391	4141	4141	4141	0.22	0.19	0.17
		40	15.6	19.5	23.6	2201	2391	2391	4141	4141	4141	0.18	0.16	0.15
		50	16.4	20.5	24.8	2379	2391	2391	4141	4141	4141	0.16	0.14	0.13
SWJMK42	E	10	18.2	23.3	28.5	1530	1723	1889	2819	3297	3724	0.65	0.57	0.51
		15	20.9	26.6	32.3	1770	1997	2194	3458	4063	4607	0.52	0.45	0.41
		20	21.9	27.7	33.5	1969	2227	2452	4002	4716	5363	0.42	0.37	0.33
		25	23.4	29.6	35.8	2129	2410	2654	4443	5242	5733	0.37	0.33	0.30
		30	23.3	29.2	35.2	2278	2583	2848	4866	5733	5733	0.32	0.28	0.26
		40	23.6	29.5	35.5	2529	2871	3171	5581	5733	5733	0.26	0.23	0.21
		50	25.0	31.2	37.4	2734	3104	3429	5733	5733	5733	0.24	0.21	0.19
SWJMK50	E	10	31.1	40.1	49.2	2048	2299	2514	3370	3923	4413	1.09	0.96	0.86
		15	35.3	45.1	54.9	2375	2677	2937	4187	4909	5556	0.86	0.75	0.67
		20	39.7	50.5	61.4	2622	2958	3248	4801	5638	6391	0.74	0.65	0.58
		25	42.3	53.6	64.9	2839	3207	3525	5355	6301	7153	0.65	0.57	0.51
		30	40.1	50.4	60.7	3057	3462	3815	5926	6994	7546	0.54	0.47	0.43
		40	44.0	55.2	66.4	3377	3826	4218	6761	7546	7546	0.46	0.41	0.37
		50	45.9	57.4	69.0	3655	4144	4572	7503	7546	7546	0.41	0.36	0.33
SWJMK63	E	10	55.0	71.3	87.2	2193	2441	2652	3227	3714	4140	1.92	1.69	1.52
		15	62.8	80.5	97.7	2552	2856	3117	4072	4739	5332	1.51	1.32	1.18
		20	69.3	88.1	107	2829	3174	3471	4721	5516	6227	1.28	1.12	1.00
		25	76.0	96.3	116	3054	3430	3753	5249	6143	6943	1.15	1.00	0.90
		30	71.9	90.5	109	3306	3726	4091	5863	6892	7823	0.95	0.83	0.74
		40	76.9	96.4	115	3666	4139	4550	6732	7928	8281	0.80	0.70	0.63
		50	83.1	104	124	3960	4474	4920	7457	8281	8281	0.72	0.63	0.57
SWJMK70	E	10	86.8	113	138	2319	2564	2768	4144	4738	5252	3.03	2.66	2.40
		15	99.2	127	154	2722	3033	3298	5284	6123	6869	2.38	2.08	1.86
		20	112	142	172	3016	3369	3671	6109	7109	7999	2.05	1.79	1.60
		25	121	154	186	3266	3655	3988	6825	7962	8977	1.83	1.59	1.43
		30	114	143	172	3560	4002	4387	7681	9010	10214	1.49	1.30	1.17
		40	125	156	187	3943	4441	4872	8804	10346	11613	1.28	1.12	1.01
		50	124	155	184	4313	4869	5356	9864	11613	11613	1.06	0.93	0.84
SWMK80	T B V	10	215	271	323	3160	3457	3705	4387	4926	5389	7.44	6.33	5.55
		15	232	293	350	3838	4236	4576	6120	7011	7799	5.51	4.72	4.16
		20	238	292	358	4385	4909	5282	7438	8676	9626	4.34	3.63	3.30
		25	240	297	360	4853	5433	5893	8553	9979	11180	3.56	3.02	2.72
		30	241	303	362	5245	5856	6386	9609	11198	12633	3.09	2.69	2.40
		40	239	293	358	5940	6693	7285	11289	13274	14955	2.40	2.05	1.88
		50	232	287	347	6548	7382	8079	12757	15008	15970	1.93	1.67	1.53
SWMK100	T B V	10	-	443	521	-	4290	4617	-	5647	6214	-	10.26	8.85
		15	-	481	569	-	5325	5762	-	8319	9271	-	7.64	6.65
		20	-	494	586	-	6149	6676	-	10377	11632	-	6.04	5.30
		25	-	495	591	-	6856	7455	-	12037	13522	-	4.94	4.37
		30	-	499	592	-	7441	8122	-	13611	15368	-	4.31	3.81
		40	-	495	588	-	8467	9265	-	16138	18273	-	3.36	3.00
		50	-	478	571	-	9385	10285	-	18327	20783	-	2.70	2.42
60	-	454	542	-	10215	11219	-	20324	21560	-	2.20	1.99		

Size : 35 • 42 • 50 • 63

Mounting position: E

Size : 70

Mounting position: E

Size : 80 to 100

Mounting position: T

Mounting position: B

Mounting position: V

- The maximum input speed is 3,000 r/min for the SWJMK35 to SWJMK70 and SWMK80 and is 2,000 r/min for the SWMK100.
- The allowable torque on output shaft for the SWJMK70, SWMK80, and SWMK100 are values during intermittent operation. Use the product with an operating time percentage (ED percentage) of 50% and for 20 minutes or less of continuous operation. During continuous operation, the rated thermal capacity must be considered, so use the sizing inquiry form on page 38 to contact us.
- It is necessary to check whether the product can be accelerated by the motor's start torque when the product starts during intermittent operation. For the starting efficiency, use a value that is half the efficiency that can be calculated from the allowable input kW and allowable torque on output shaft.
- Servo motors that exceed the values listed above can be supported by the Worm Power Drive SWM Series. For details, use the sizing inquiry form on page 38 to contact us.
- For details on the moment of inertia on input shaft and backlash, see page 30.
- For sections indicated by , the allowable torque of the coupling connecting the servo motor and the reducer may be exceeded depending on the used mount code. For details, see the allowable coupling torque listed in the mount dimensions on page 24.

Dimensions

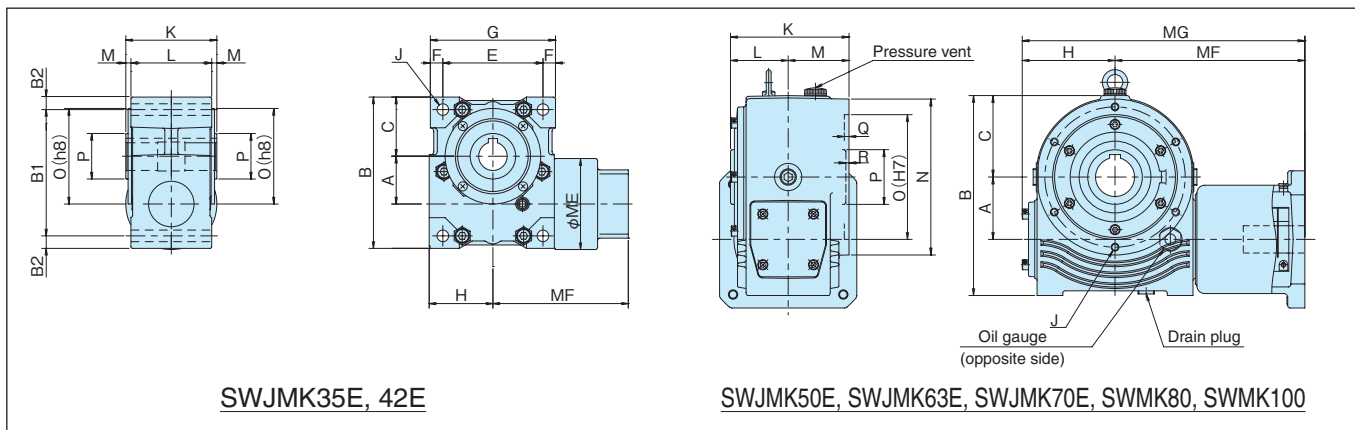

Unit: mm

Size	A	B	B1	B2	C	E	F	G	H	J	K	L	M	N	O	P	Q	R
SWJMK	35	35	115	96	9.5	45	71	9.5	90	Through-hole for 4-M8 bolts	70	65	2.5	-	72	30	-	-
	42	42	133	111	11	52	88	11	110	Through-hole for 4-M10 bolts	80	71	4.5	-	84	40	-	-
	50	50	180	-	-	72	-	-	74	4-M8-16L(PCD120)	112	56	56	138	100	45	5	2
	63	63	220	-	-	87	-	-	90	4-M10-18L(PCD145)	132	66	66	165	120	48	5	2
	70	70	240	-	-	92	-	-	112	6-M8-15L(PCD157)	135	65	70	177	137	58	5	5
SWMK	80	80	256.5	-	-	104.5	-	-	119	6-M10-20L(PCD180)	152	74	78	200	160	70	6	4
	100	100	296	-	-	120	-	-	140	6-M10-20L(PCD205)	177	87	90	230	185	80	7	3

Note) The above diagrams show the dimensions for mounting position B. For mounting positions T and V, the positions of the pressure vent and oil gauge are different from those shown in the above diagrams.

Sizes 35, 42, 50, 63, and 70 can be installed in any position (mounting position E) and do not have a pressure vent or oil gauge.

Sizes 35, 42, 50, and 63 are double faced flange types.

Unit: mm

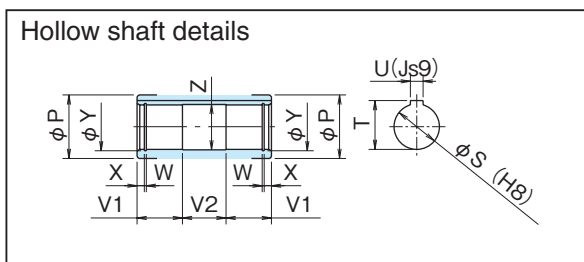

Size	S	T	U	V1	V2	W	X	Y	Z
SWJMK	35	20	22.8	6	25	20	-	-	21
	42	25	28.3	8	28	24	-	-	26
	50	30	33.3	8	35	38	1.35	5	31.4
	63	35	38.3	10	40	48	1.65	6	37
	70	40	43.3	12	45	40	1.95	7	42.5
SWMK	80	50	53.8	14	50	48	2.2	8	53
	100	55	59.3	16	60	54	2.2	8	58

Worm Gear Head
SWJMK/SWMK

Mount Dimensions

Unit: mm

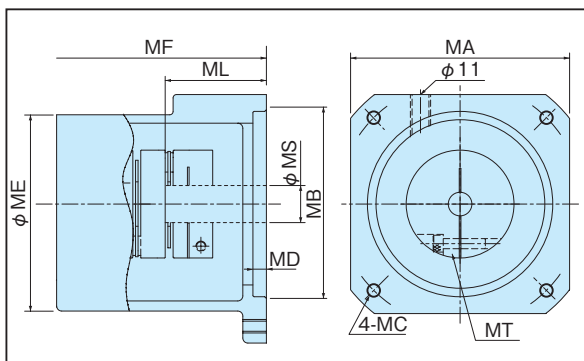

Connection coupling size	Allowable input torque on coupling N·m
NES70W	7
NES250W	25
NES800W	80
NES1300W	130

Note) For details on the support of the servo motors of various companies, see pages 11 and 12.

Note) Contact us for details on servo motors that have dimensions other than those listed to the right.

Note) Use this product in combination with the servo motor to connect to such that the value "maximum torque of the servo motor to connect to × 1.5" is less than or equal to the allowable input torque on coupling.

Size	Mount code	Connection coupling size	Motor mount dimensions																		
			MA	MB	MC	MD	ME	MF	MG	ML	MS	MT									
SWJMK35	E4DC	NES70W	□60	φ50G7	M5 10 deep (PCD70)	5	80	109	155	25	φ8	M3									
	30									φ14											
SWJMK42	E4DC	NES70W	□60	φ50G7	M5 10 deep (PCD70)	5	80	119	175	25	φ8	M3									
	30									φ14											
SWJMK50	G2HC	NES250W	□80	φ70G7	M6 10 deep (PCD90)	5	-	160	234	30	φ14	M4									
	40									φ19											
SWJMK63	G5LC	NES250W	□80	φ70G7	M6 10 deep (PCD90)	5	-	177	267	30	φ14	M4									
	40									φ19											
	K2LC									NES800W	□130		φ110G7	M8 13 deep (PCD145)	5	-	220	310	40	φ19	M6
	55																		φ24		
	55																		φ22		
L1MC	NES1300W	□176	φ114.3G7	M12 16 deep (PCD200)	8	-	229	319	55	φ28	M6										
79									φ35												
SWJMK70	G2HC	NES250W	□80	φ70G7	M6 10 deep (PCD90)	5	-	183	295	30	φ14	M4									
	40									φ19											
	K2LC									NES800W	□130		φ110G7	M8 13 deep (PCD145)	5	-	226	338	40	φ19	M6
	55																		φ24		
	55																		φ22		
L1MC	NES1300W	□176	φ114.3G7	M12 16 deep (PCD200)	8	-	235	347	55	φ28	M6										
79									φ35												
SWMK80	K2LC	NES800W	□130	φ110G7	M8 13 deep (PCD145)	5	-	233	352	40	φ19	M6									
	55									φ24											
	55									φ22											
SWMK100	L1MC	NES1300W	□176	φ114.3G7	M12 16 deep (PCD200)	8	-	244	363	55	φ28	M6									
	79									φ35											
	79									φ35											

Models

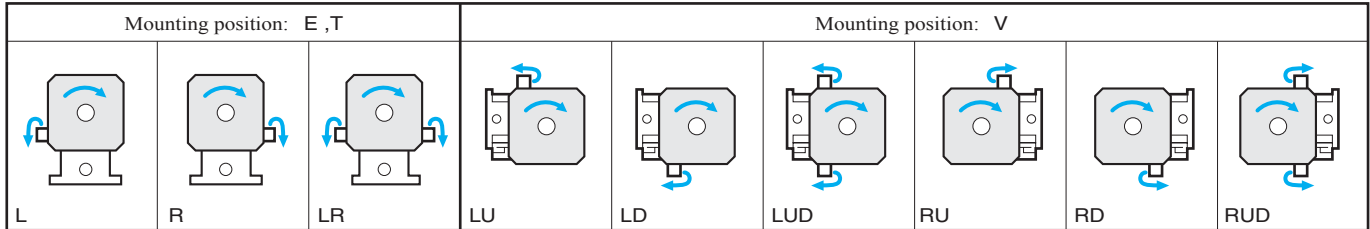
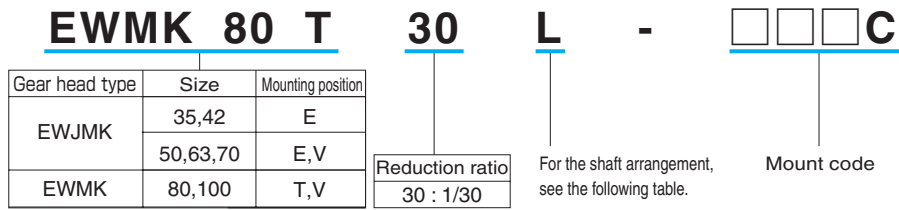

Capacity Table, EWJMK35 to EWJMK70

Size	Mounting direction	Reduction ratio (actual reduction ratio)	Allowable torque on output shaft N*m			Allowable radial load N			Allowable input kW		
			Input speed r/min			Input speed r/min			Input speed r/min		
			3000	2000	1500	3000	2000	1500	3000	2000	1500
EWJMK35	E	10	12.2	15.7	19.2	922	1029	1119	0.44	0.38	0.35
		15	13.9	17.7	21.6	1072	1202	1311	0.35	0.30	0.27
		20	14.5	18.4	22.3	1193	1341	1467	0.28	0.25	0.23
		25	15.5	19.6	23.8	1292	1455	1593	0.25	0.22	0.20
		30	15.4	19.4	23.5	1392	1571	1604	0.22	0.19	0.17
		40	15.6	19.5	23.6	1547	1604	1604	0.18	0.16	0.15
		50	16.4	20.5	24.8	1604	1604	1604	0.16	0.14	0.13
		60	16.2	20.3	24.4	1604	1604	1604	0.14	0.13	0.12
EWJMK42	E	10	18.2	23.3	28.5	1289	1446	1579	0.65	0.57	0.51
		15	20.9	26.6	32.3	1493	1680	1724	0.52	0.45	0.41
		20	21.9	27.7	33.5	1665	1724	1724	0.42	0.37	0.33
		25	23.4	29.6	35.8	1724	1724	1724	0.37	0.33	0.30
		30	23.3	29.2	35.2	1724	1724	1724	0.32	0.28	0.26
		40	23.6	29.5	35.5	1724	1724	1724	0.26	0.23	0.21
		50	25.0	31.2	37.4	1724	1724	1724	0.24	0.21	0.19
		60	26.0	32.4	38.9	1724	1724	1724	0.21	0.19	0.18
EWJMK50	E	10	62.7	78.4	90.8	1852	2047	2238	2.21	1.87	1.60
		15	67.8	84.6	97.6	2215	2464	2685	1.65	1.40	1.20
		20	68.2	86.2	98.1	2527	2685	2685	1.27	1.10	0.93
		25	69.0	86.5	98.0	2685	2685	2685	1.06	0.92	0.77
	V	30	67.8	86.2	100.5	2685	2685	2685	0.91	0.81	0.70
		40	68.4	86.2	97.9	2685	2685	2685	0.72	0.64	0.55
		50	66.7	83.4	94.3	2685	2685	2685	0.59	0.52	0.45
		60	63.4	78.9	89.0	2685	2685	2685	0.49	0.43	0.37
EWJMK63	E	10	113	140	169	2850	3190	3481	3.96	3.32	2.59
		15	122	152	182	3305	3714	4069	2.94	2.49	2.21
		20	126	157	186	3658	4120	4154	2.33	1.99	1.75
		25	127	159	186	3948	4154	4154	1.92	1.65	1.44
	V	30	126	158	188	4154	4154	4154	1.67	1.44	1.29
		40	126	157	186	4154	4154	4154	1.30	1.14	1.02
		50	122	153	179	4154	4154	4154	1.05	0.93	0.82
		60	116	145	168	4154	4154	4154	0.87	0.77	0.68
EWJMK70	E	10	149	182	225	3306	3698	3951	5.21	4.30	3.90
		15	161	198	242	3955	4437	4785	3.87	3.23	2.92
		20	166	206	248	4480	5023	5466	3.05	2.59	2.32
		25	167	209	248	4930	5533	5674	2.51	2.16	1.91
	V	30	167	205	250	5310	5674	5674	2.18	1.86	1.70
		40	166	206	248	5674	5674	5674	1.70	1.47	1.34
		50	161	201	239	5674	5674	5674	1.38	1.21	1.09
		60	153	192	226	5674	5674	5674	1.13	1.00	0.90

Capacity Table, EWMK80 and EWMK100

Size	Mounting direction	Reduction ratio (actual reduction ratio)	Allowable torque on output shaft N·m			Allowable radial load N			Allowable input kW		
			Input speed r/min			Input speed r/min			Input speed r/min		
			3000	2000	1500	3000	2000	1500	3000	2000	1500
EWMK80	T V	10	215	271	323	7575	7575	7575	7.44	6.33	5.55
		15	232	293	350	7575	7575	7575	5.51	4.72	4.16
		20	238	292	358	7575	7575	7575	4.34	3.63	3.30
		25	240	297	360	7575	7575	7575	3.56	3.02	2.72
		30	241	303	362	7575	7575	7575	3.09	2.69	2.40
		40	239	293	358	7575	7575	7575	2.40	2.05	1.88
		50	232	287	347	7575	7575	7575	1.93	1.67	1.53
		60	220	274	326	7575	7575	7575	1.57	1.38	1.25
EWMK100	T V	10	–	443	521	–	11505	11505	–	10.26	8.85
		15	–	481	569	–	11505	11505	–	7.64	6.65
		20	–	494	586	–	11505	11505	–	6.04	5.30
		25	–	495	591	–	11505	11505	–	4.94	4.37
		30	–	499	592	–	11505	11505	–	4.31	3.81
		40	–	495	588	–	11505	11505	–	3.36	3.00
		50	–	478	571	–	11505	11505	–	2.70	2.42
		60	–	454	542	–	11505	11505	–	2.20	1.99

- The maximum input speed is 3,000 r/min for the EWJMK35 to EWJMK70 and EWMK80 and is 2,000 r/min for the EWMK100.
- The allowable torque on output shaft for the EWJMK70, EWMK80, and EWMK100 are values during intermittent operation. Use the product with an operating time percentage (ED percentage) of 50% and for 20 minutes or less of continuous operation. During continuous operation, the rated thermal capacity must be considered, so use the sizing inquiry form on page 38 to contact us.
- It is necessary to check whether the product can be accelerated by the motor's start torque when the product starts during intermittent operation. For the starting efficiency, use a value that is half the efficiency that can be calculated from the allowable input kW and allowable torque on output shaft.
- Servo motors that exceed the values listed above can be supported by the Worm Power Drive EWM Series. For details, use the sizing inquiry form on page 38 to contact us.
- For details on the moment of inertia on input shaft and backlash, see page 30.
- For sections indicated by , the allowable torque of the coupling connecting the servo motor and the reducer may be exceeded depending on the used mount code. For details, see the allowable coupling torque listed in the mount dimensions on page 27.

Dimensions

EWJMK35 and EWJMK42

EWJMK50 to EWJMK70, EWMK80, and EWMK100

*Tsubaki offers optional mounting bolts and mounting feet. See page 27.

For details on the output shaft taps, see the following diagrams.

Unit: mm

Size	A	B	B1	B2	C	D	E	F	H	J	K	L	M	N	O	P	Q	R	S	
EWJMK	35	35	115	96	9.5	45	90	71	9.5	46	8	65	32.5	1.5	106	34	72	36	30	18
	42	42	133	111	11	52	110	88	11	56	10	71	35.5	3	124.5	38.5	86	44	38	22
	50	50	198	–	–	80	144	112	16	74	9	110	88	11	160	108	52	50	40	25
	63	63	239	–	–	98	174	136	19	90	11	126	104	11	185	122	63	60	50	30
	70	70	250	–	–	100	180	142	19	94	14	132	104	14	200	124	76	70	55	35
EWMK	80	80	275	–	–	110	200	165	17.5	100	14	144	114	15	228	148	80	75	60	38
	100	100	324	–	–	124	234	194	20	117	16	166	132	17	263	170	93	90	75	45

Output shaft taps

EWJMK35, EWJMK42, EWJMK50,
EWJMK63, and EWJMK70

EWMK80 and EWMK100

Size	T	U	Y	Z	
EWJMK	35	6 x 6 keyway	–	M6 12 deep	–
	42	6 x 6 keyway	–	M8 16 deep	–
	50	8 x 7 keyway	11	M8 16 deep	–
	63	8 x 7 keyway	13	M10 20 deep	–
	70	10 x 8 keyway	15	M10 20 deep	–
EWMK	80	10 x 8 keyway	17	M8 16 deep x 2	20
	100	14 x 9 keyway	20	M10 20 deep x 2	22

Motor Mount Dimensions

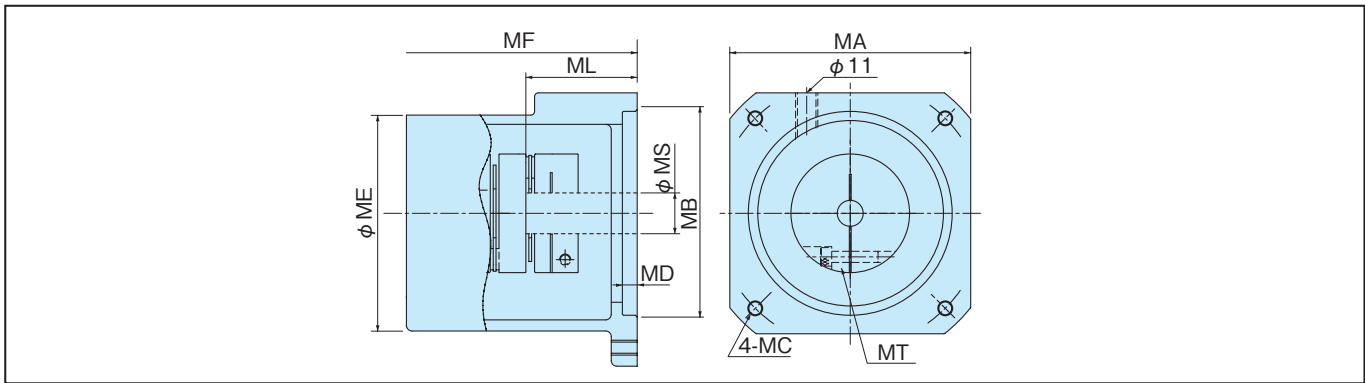

Unit: mm

Size	Mount code	Connection coupling size	Allowable input torque on coupling N·m	Motor mount dimensions									
				MA	MB	MC	MD	ME	MF	MG	ML	MS	MT
EWJMK35	E4DC	NES70W	7	□60	φ50G7	M5 10 deep	5	80	109	155	25	φ8	M3
	30										φ14		
EWJMK42	E4DC	NES70W	7	□60	φ50G7	M5 10 deep (PCD70)	5	80	119	175	25	φ8	M3
	30										φ14		
EWJMK50	G2HC	NES250W	25	□80	φ70G7	M6 10 deep (PCD90)	5	85	157	231	30	φ14	M4
	G5LC										40	φ19	
EWJMK63	G5LC	NES250W	25	□80	φ70G7	M6 10 deep (PCD90)	5	-	177	267	40	φ19	M4
	K2LC	NES800W	80	□130	φ110G7	M8 13 deep (PCD145)	5	-	220	310	40	φ19	M6
	K3YC										55	φ24	
	L1MC	NES1300W	130	□176	φ114.3G7	M12 16 deep (PCD200)	8	-	229	319	55	φ22	M6
	L1PC										55	φ28	
L1RC	79										φ35		
EWJMK70	K2LC	NES800W	80	□130	φ110G7	M8 13 deep (PCD145)	5	-	226	320	40	φ19	M6
	K3YC										55	φ24	
	L1MC	NES1300W	130	□176	φ114.3G7	M12 16 deep (PCD200)	8	-	235	329	55	φ22	M6
	L1PC										55	φ28	
	L1RC										79	φ35	
EWMK80	K2LC	NES800W	80	□130	φ110G7	M8 13 deep (PCD145)	5	-	233	333	40	φ19	M6
	K3YC										55	φ24	
	L1MC	NES1300W	130	□176	φ114.3G7	M12 16 deep (PCD200)	8	-	244	344	55	φ22	M6
	L1PC										55	φ28	
	L1RC										79	φ35	
EWMK100	L1MC	NES1300W	130	□176	φ114.3G7	M12 16 deep (PCD200)	8	-	262	379	55	φ22	M6
	L1PC										55	φ28	
	L1RC										79	φ35	

Note) For details on the support of the servo motors of various companies, see pages 11 and 12.

Note) Contact us for details on servo motors that have dimensions other than those listed above.

Note) Use this product in combination with the servo motor to connect to such that the value "maximum torque of the servo motor to connect to × 1.5" is less than or equal to the allowable input torque on coupling.

Mounting Bolts, EWJMK/SWJMK Type

Unit: mm

Tsubaki offers standard bolts for flange mounting, available for separate purchase as an optional item.

Flange mount bolts are available in the sizes shown in the table on the right.

Bolts are shipped with matching nuts.

Model no.	Applicable size	Pieces	Bolt size
J35-FMB	EWJMK35 SWJMK35	4	M8 × 80
J42-FMB	EWJMK42 SWJMK42	4	M10 × 90

Mounting Feet, EWJMK Type

Tsubaki offers mounting feet available for separate purchase as an optional item. Feet can also be factory mounted to reducers as a special order.

When shipped as an optional item, two feet are supplied complete with two sets of mounting bolts and nuts.

Unit: mm

Standard dimensions of mounting feet are shown in the table to the right.

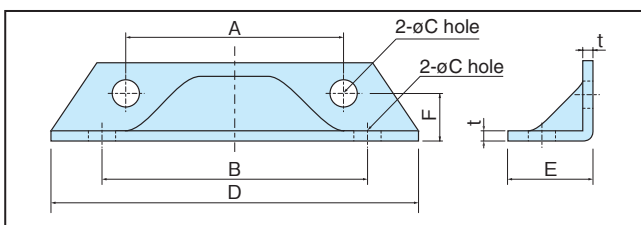

Model no.	Applicable size	A	B	C	D	E	F	t	Bolt size
EWJ35-L	EWJMK35	71	96	8.2	120	27.5	15	3.2	M8 × 80
EWJ42-L	EWJMK42	88	111	10.2	135	37	23	3.2	M10 × 90

*Mounting feet have been surface treated and are supplied unpainted.

TERVO

Technical Data



Contents

- ◎ Moment of Inertia on Input Shaft
 - Hypoid Gear Heads and Helical Gear Heads Page 29
 - Worm Gear Heads Page 30
- ◎ Output Shaft Backlash
 - Hypoid Gear Heads and Helical Gear Heads Page 30
 - Worm Gear Heads Page 30
- ◎ Hollow-Shaft POWER-LOCK Specifications
 - Hypoid Gear Heads Page 31

Moment of Inertia on Input Shaft (Hypoid Gear Heads and Helical Gear Heads)

Hypoid gear head HMTK type

Model no.	Moment of inertia $\times 10^{-4}$ kg·m ²	
	(GD ²)	($\times 10^{-4}$ kgf·m ²)
HMTK0220H	5	0.87 (3.46)
	10	0.81 (3.25)
	15	0.80 (3.19)
	20	0.79 (3.17)
	25	0.79 (3.15)
	30	0.79 (3.15)
	40	0.79 (3.14)
	50	0.79 (3.14)
HMTK0230H	60	0.78 (3.14)
	80	0.73 (2.90)
	100	0.72 (2.90)
	120	0.72 (2.89)
	160	0.72 (2.89)
	200	0.72 (2.89)
HMTK0430H	5	1.05 (4.20)
	10	0.98 (3.90)
	15	0.94 (3.74)
	20	0.92 (3.68)
	25	0.91 (3.64)
	30	0.91 (3.63)
	40	0.92 (3.66)
	50	0.91 (3.65)
HMTK0435H*	60	0.81 (3.26)
	80	0.81 (3.24)
	100	0.81 (3.23)
	120	0.80 (3.21)
	160	0.80 (3.21)
HMTK0735H*	200	0.80 (3.21)
	5	3.17 (12.68)
	10	2.74 (11.0)
	15	2.64 (10.57)
	20	2.60 (10.42)
	25	2.58 (10.32)
	30	2.57 (10.3)
	40	2.59 (10.37)
HMTK0745H	50	2.58 (10.32)
	60	2.32 (9.27)
	80	2.31 (9.23)
	100	2.30 (9.21)
	120	2.28 (9.12)
	160	2.28 (9.11)
HMTK1545H	200	2.28 (9.11)
	5	6.55 (26.2)
	10	5.60 (22.4)
	15	5.38 (21.5)
	20	5.28 (21.1)
	25	5.22 (20.9)
	30	5.18 (20.7)
	40	5.27 (21.1)
	50	5.25 (21.0)
	60	5.22 (20.9)
HMTK1555H	80	5.21 (20.8)
	100	5.77 (23.1)
	120	5.69 (22.7)
	160	5.68 (22.7)
HMTK2245H	200	5.67 (22.7)
	5	17.7 (70.9)
	10	16.8 (67.2)
	15	16.6 (66.3)
	20	16.5 (65.8)
	25	16.7 (66.8)
	30	16.5 (66.0)
	40	16.5 (65.8)
	50	16.4 (65.6)
	60	16.4 (65.5)
HMTK2255H	80	17.1 (68.2)
	100	17.0 (68.0)
	120	17.0 (67.8)

Model no.	Moment of inertia $\times 10^{-4}$ kg·m ²	
	(GD ²)	($\times 10^{-4}$ kgf·m ²)
HMTK0222U	5	0.88 (3.50)
	10	0.82 (3.26)
	15	0.80 (3.19)
	20	0.79 (3.17)
	25	0.79 (3.15)
	30	0.79 (3.15)
	40	0.79 (3.14)
	50	0.79 (3.14)
HMTK0228U	60	0.78 (3.14)
	80	0.73 (2.90)
	100	0.72 (2.90)
	120	0.72 (2.89)
	160	0.72 (2.89)
	200	0.72 (2.89)
HMTK0428U	5	1.05 (4.20)
	10	0.99 (3.97)
	15	0.94 (3.77)
	20	0.92 (3.70)
	25	0.91 (3.65)
	30	0.91 (3.63)
	40	0.92 (3.67)
	50	0.91 (3.65)
HMTK0438U*	60	0.82 (3.26)
	80	0.81 (3.24)
	100	0.81 (3.23)
	120	0.80 (3.22)
	160	0.80 (3.21)
HMTK0738U*	200	0.80 (3.21)
	5	3.33 (13.3)
	10	2.78 (11.1)
	15	2.66 (10.7)
	20	2.61 (10.5)
	25	2.59 (10.4)
	30	2.58 (10.3)
	40	2.60 (10.4)
HMTK0742U	50	2.58 (10.3)
	60	2.32 (9.28)
	80	2.31 (9.24)
	100	2.30 (9.21)
	120	2.28 (9.12)
	160	2.28 (9.11)
HMTK1542U	200	2.28 (9.11)
	5	6.95 (27.8)
	10	5.70 (22.8)
	15	5.43 (21.7)
	20	5.30 (21.2)
	25	5.24 (21.0)
	30	5.19 (20.8)
	40	5.28 (21.1)
	50	5.25 (21.0)
	60	5.22 (20.9)
HMTK1550U	80	5.21 (20.9)
	100	5.80 (23.2)
	120	5.69 (22.8)
	160	5.68 (22.7)
HMTK2242U	200	5.67 (22.7)
	5	18.1 (72.5)
	10	16.9 (67.6)
	15	16.6 (66.5)
	20	16.5 (66.0)
	25	16.7 (66.9)
	30	16.5 (66.0)
	40	16.5 (65.9)
	50	16.4 (65.6)
	60	16.4 (65.5)
HMTK2250U	80	17.1 (68.2)
	100	17.0 (68.0)
	120	17.0 (67.9)

Helical gear head GMTK type

Model no.	Moment of inertia $\times 10^{-4}$ kg·m ²		
	Reduction ratio	Actual reduction ratio	Moment of inertia (GD ²)
GMTK0218	5	5.031	0.741 (2.97)
	10	9.779	0.714 (2.86)
	15	14.800	0.709 (2.84)
	20	19.821	0.707 (2.83)
	25	24.843	0.707 (2.83)
GMTK0224	30	29.464	0.713 (2.85)
	40	39.030	0.706 (2.82)
	50	49.407	0.706 (2.82)
	60	59.417	0.705 (2.82)
	75	72.286	0.705 (2.82)
GMTK0228	100	97.785	0.709 (2.83)
	120	120.653	0.709 (2.83)
	165	160.136	0.708 (2.83)
	200	194.775	0.708 (2.83)
	GMTK0424	5	4.950
10		10.313	0.783 (3.13)
15		15.125	0.770 (3.08)
20		19.388	0.766 (3.06)
25		24.750	0.765 (3.06)
GMTK0428	30	30.875	0.777 (3.11)
	40	40.519	0.761 (3.04)
	50	50.909	0.760 (3.04)
	60	60.000	0.760 (3.04)
	75	73.247	0.759 (3.03)
GMTK0438	100	101.544	0.784 (3.14)
	120	117.113	0.784 (3.13)
	165	160.705	0.783 (3.13)
	200	192.560	0.782 (3.13)
	GMTK0728*	5	5.061
10		10.159	2.41 (9.63)
15		14.694	2.36 (9.45)
20		19.948	2.34 (9.34)
25		25.397	2.32 (9.28)
GMTK0738*	30	30.381	2.29 (9.16)
	40	40.635	2.37 (9.48)
	50	49.143	2.37 (9.47)
	60	60.082	2.36 (9.46)
	75	74.667	2.36 (9.45)
GMTK0742*	100	96.281	2.44 (9.76)
	120	122.500	2.44 (9.76)
	165	160.821	2.44 (9.75)
	200	197.980	2.44 (9.74)
	GMTK1538	5	5.000
10		10.000	4.45 (17.8)
15		15.000	4.29 (17.2)
20		19.615	4.21 (16.9)
25		24.091	4.17 (16.7)
GMTK1542	30	30.000	4.14 (16.6)
	40	39.253	4.25 (17)
	50	48.704	4.24 (17)
	60	61.492	4.24 (16.9)
	75	72.859	4.23 (16.9)
GMTK2242	5	5.000	16.3 (65.2)
	10	9.870	16.0 (64.1)
	15	14.454	15.9 (63.5)
	20	20.659	15.8 (63.0)
	25	25.455	15.7 (62.9)
	30	29.143	15.7 (62.7)

Note) The moment of inertia, GD², is a standalone value for the gear head and is converted to the moment of inertia on input shaft (motor shaft).

Regarding items indicated by the "*" symbol, for mount code "K3YC" flanges, add 1.48×10^{-4} kg·m² (5.9×10^{-4} kgf·m²) to the values listed in the above table.

Moment of Inertia on Input Shaft (Worm Gear Heads)

Worm gear head SWJMK/SWMK type

Moment of inertia $\times 10^{-4} \text{ kg}\cdot\text{m}^2$
(GD²) $(\times 10^{-4} \text{ kgf}\cdot\text{m}^2)$

Size	SWJMK35	SWJMK42	SWJMK50	SWJMK63			SWJMK70			SWMK80		SWMK100	
	Flange □ 60	□ 60	□ 80	□ 80	□ 130	□ 176	□ 80	□ 130	□ 176	□ 130	□ 176	□ 176	
Reduction ratio	10	0.363	0.468	2.39	5.31	7.32	15.4	4.59	6.54	14.5	11.7	19.7	31.8
		(1.45)	(1.87)	(9.56)	(21.3)	(29.3)	(61.5)	(18.4)	(26.2)	(58.0)	(46.8)	(78.6)	(127)
	15	0.350	0.432	2.32	5.15	7.16	15.2	4.29	6.25	14.2	11.1	19.0	30.2
		(1.40)	(1.73)	(9.28)	(20.6)	(28.6)	(60.8)	(17.2)	(25.0)	(56.8)	(44.3)	(76.2)	(121)
	20	0.347	0.423	2.24	4.95	6.96	15.0	4.28	6.24	14.2	10.5	18.4	28.8
		(1.39)	(1.69)	(8.96)	(19.8)	(27.8)	(60.0)	(17.1)	(24.9)	(56.8)	(41.8)	(73.7)	(115)
	25	0.343	0.412	2.21	4.83	6.83	14.9	3.90	5.85	13.8	10.1	18.0	27.8
		(1.37)	(1.65)	(8.84)	(19.3)	(27.3)	(59.5)	(15.6)	(23.4)	(55.3)	(40.3)	(72.1)	(111)
	30	0.344	0.414	2.28	5.06	7.06	15.1	4.12	6.07	14.0	10.7	18.7	29.2
		(1.37)	(1.66)	(9.12)	(20.2)	(28.3)	(60.5)	(16.5)	(24.3)	(56.1)	(42.9)	(74.7)	(117)
	40	0.343	0.413	2.22	4.90	6.90	15.0	4.19	6.14	14.1	10.3	18.2	28.2
		(1.37)	(1.65)	(8.87)	(19.6)	(27.6)	(59.8)	(16.7)	(24.5)	(56.4)	(41.0)	(72.9)	(113)
50	0.341	0.406	2.20	4.79	6.80	14.8	3.83	5.78	13.8	9.94	17.9	27.5	
	(1.36)	(1.62)	(8.78)	(19.2)	(27.2)	(59.4)	(15.3)	(23.1)	(55.0)	(39.8)	(71.6)	(110)	
60	0.342	0.402	2.18	4.75	6.75	14.8	3.64	5.59	13.6	9.52	17.5	26.5	
	(1.37)	(1.61)	(8.74)	(19.0)	(27.0)	(59.2)	(14.6)	(22.4)	(54.2)	(38.1)	(69.9)	(106)	

Note) The moment of inertia, GD², is a standalone value for the gear head and is converted to the moment of inertia on input shaft (motor shaft).

Worm gear head EWJMK/EWMK type

Moment of inertia $\times 10^{-4} \text{ kg}\cdot\text{m}^2$
(GD²) $(\times 10^{-4} \text{ kgf}\cdot\text{m}^2)$

Size	EWJMK35	EWJMK42	EWJMK50	EWJMK63			EWJMK70		EWMK80		EWMK100	
	Flange □ 60	□ 60	□ 80	□ 80	□ 130	□ 176	□ 130	□ 176	□ 130	□ 176	□ 176	
Reduction ratio	10	3.58	4.50	3.11	5.29	7.30	15.3	9.90	18.0	11.4	19.3	31.2
		(14.3)	(18.0)	(12.4)	(21.2)	(29.2)	(61.4)	(39.6)	(71.8)	(45.5)	(77.4)	(125)
	15	3.48	4.24	3.06	5.14	7.15	15.2	9.67	17.7	10.9	18.9	29.9
		(13.9)	(17.0)	(12.2)	(20.6)	(28.6)	(60.8)	(38.7)	(70.9)	(43.8)	(75.6)	(120)
	20	3.46	4.18	2.99	4.95	6.95	15.0	9.27	17.3	10.4	18.4	28.6
		(13.8)	(16.7)	(11.9)	(19.8)	(27.8)	(60.0)	(37.1)	(69.3)	(41.5)	(73.4)	(114)
	25	3.42	4.09	2.96	4.83	6.83	14.9	9.09	17.1	10.0	18.0	27.7
		(13.7)	(16.4)	(11.8)	(19.3)	(27.3)	(59.5)	(36.4)	(68.6)	(40.1)	(72.0)	(111)
	30	3.43	4.12	3.03	5.06	7.06	15.1	9.53	17.6	10.7	18.6	29.2
		(13.7)	(16.5)	(12.1)	(20.2)	(28.2)	(60.4)	(38.1)	(70.3)	(42.7)	(74.6)	(117)
	40	3.43	4.12	2.97	4.90	6.90	15.0	9.20	17.2	10.2	18.2	28.2
		(13.7)	(16.5)	(11.9)	(19.6)	(27.6)	(59.8)	(36.8)	(69.0)	(41.0)	(72.8)	(113)
50	3.40	4.05	2.95	4.79	6.80	14.8	9.04	17.1	9.93	17.9	27.4	
	(13.6)	(16.2)	(11.8)	(19.2)	(27.2)	(59.4)	(36.2)	(68.4)	(39.7)	(71.6)	(110)	
60	3.41	4.01	2.94	4.75	6.75	14.8	8.96	17.0	9.51	17.5	26.5	
	(13.7)	(16.0)	(11.7)	(19.0)	(27.0)	(59.2)	(35.8)	(68.0)	(38.0)	(69.9)	(106)	

Note) The moment of inertia, GD², is a standalone value for the gear head and is converted to the moment of inertia on input shaft (motor shaft).

Output Shaft Backlash

Hypoid gear head HMTK type

Units: arcmin

Reduction ratio	5 to 10	15 to 100	120 to 200
Angle	60	30	20

These are approximate values. These values are not guaranteed.

Helical gear head GMTK type

Units: arcmin

Reduction ratio	5 to 10	15 to 100	120 to 200
Angle	70	40	30

These are approximate values. These values are not guaranteed.

Worm gear head SWJMK/SWMK type

Units: arcmin

Size	SWJMK35	SWJMK42	SWJMK50	SWJMK63	SWJMK70	SWMK80	SWMK100
Angle	40	30	25	20		15	

These are approximate values. These values are not guaranteed.

Worm gear head EWJMK/EWMK type

Units: arcmin

Size	EWJMK35	EWJMK42	EWJMK50	EWJMK63	EWJMK70	EWMK80	EWMK100
Angle	40	30	25		35	30	25

These are approximate values. These values are not guaranteed.

Hollow-Shaft POWER-LOCK Type (Specification Code: K)

Hypoid gear head HMTK type

A special hollow shaft with POWER-LOCK enables keyless coupling and gives rise to further hollow shaft functions. Mounting and unmounting are easy, and a reduced number of machinery device parts helps save space.

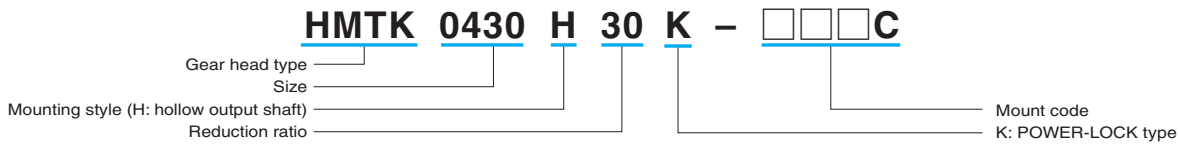

Features

- There's no need for a keyway on the driven shaft.
- Mounting and unmounting of the reducer are easy.
- There's no backlash with the driven shaft.
- A special shaft-end cover is available. (Hypoid motor: 0.2 kW to 0.4 kW, 0.75 kW, reduction ratios 1/5 to 1/50 only)

Hypoid gear head specifications

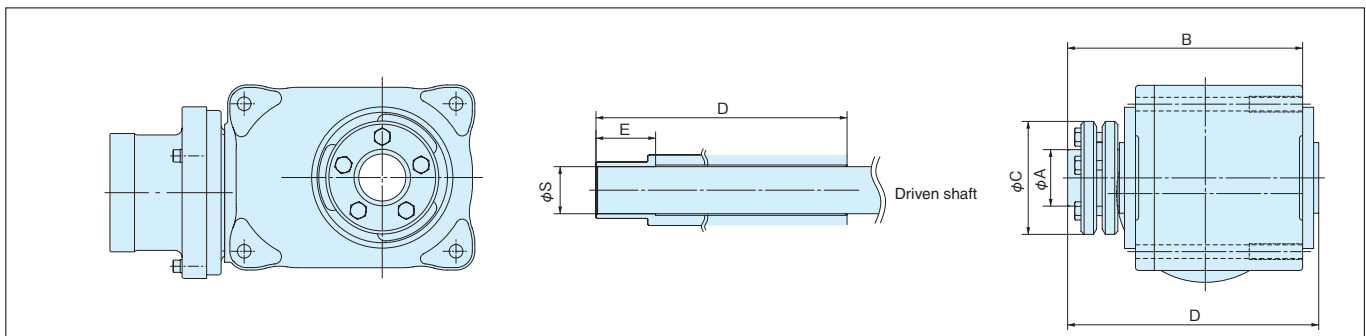

Model no.	Reduction ratio	ϕS	ϕA	ϕC	E	D	B	POWER-LOCK model number	Bolt size	Tightening torque MA N·m (kgf·m)
HMTK02	1/5~1/60	20	30	60	31	122.5	118	PL030×060SL	M5×18	4.9 (0.15)
	1/80~1/200	30	36	72	38	160	150	PL036×072SL	M6×20	11.8 (1.2)
HMTK04	1/5~1/50									
	HMTK075	1/60~1/200	35	44	80	44	188	178	PL044×080SL	M6×20
HMTK15		1/5~1/50	45	55	100	45	210	200	PL055×100SL	M6×25
	1/60~1/200									
	1/5~1/80									

Note 1 The driven shaft to be coupled to the hypoid motor hollow shaft should have a dimensional tolerance of ϕS h6, a finish length of dimension E or longer, and a surface roughness of 12S or less. The finished surface of the driven shaft should be located within the range indicated by E.

Note 2 For 0.2 to 0.4 kW and 1/5 to 1/50 of 0.75 kW, a special shaft-end cover is available.

TERVO

Handling

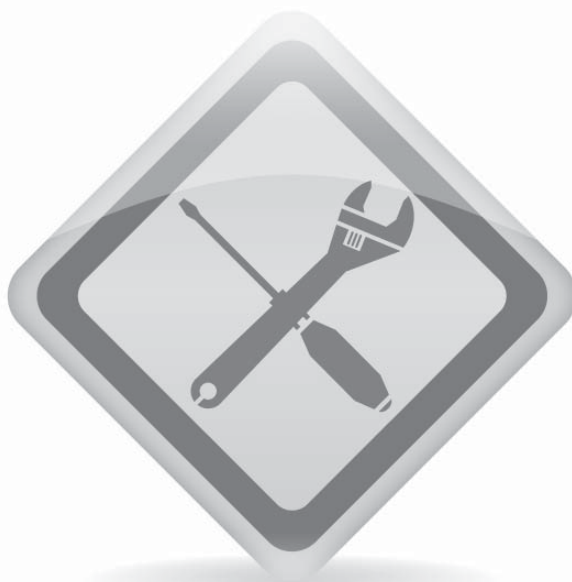

Contents

Handling	Pages 33 to 37
Inquiry Form	Page 38

This section contains general information regarding the handling of the TERVO HMTK, GMTK, SWJMK, SWMK, EWJMK, and EWMK Series. For details, see the manual supplied with the product.

■ Upon receipt of your product

Check the following items upon receipt of your reducer. Contact your distributor if any defects are found or if you have any questions.

- (1) Verify that the specifications on the nameplate correspond to your order. Pay special attention to the shaft arrangement and rotational direction. Check these against the positions of the input and output shafts, oil gauge, and plugs.
- (2) Make sure all accessories, such as pressure vents, are included.
- (3) Visually inspect the product for damage sustained during transport.
- (4) Make sure there are no loose screws or nuts.

1. Nameplate

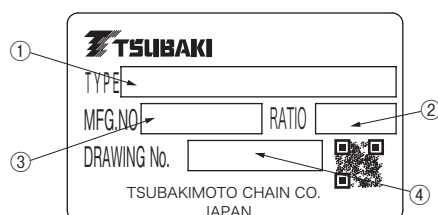

When contacting Tsubaki, please provide us with: (1) TYPE (the model number), (2) RATIO (the reduction ratio), (3) MFG.NO (the manufacturer's serial number), and (4) DRAWING NO. (the drawing number).

2. Model number designation

Make sure that the model number of the unit delivered matches your order.

■ Storage

If you will not use the reducer immediately upon delivery, store it by observing the following precautions.

1. Storage location

Store the product in a clean and dry indoor environment.

Do not store the product outside or in locations in which it may be exposed to humidity, dust, extreme temperature fluctuations, or corrosive gases.

2. Storage position

The product is packed and shipped in its final mounting position. Store it as delivered, in the upright position. If products with special installation styles are stored in the wrong position or direction, the bearing grease and lubrication may mix or leak from the unit.

3. Storage period

- (1) The maximum storage period is six months.
- (2) Special anti-rust treatment is required for storage lasting longer than six months. Contact us for details.
- (3) Anti-rust treatment for export models is special and must be done prior to export. Contact us for details.

4. Operating the product after storage

- (1) Non-metallic parts like oil seals, oil gauges, and oil plugs wear out easily due to environmental conditions such as extreme temperatures and ultraviolet rays. Before operation after a long period of storage, inspect these parts and replace them if damaged.
- (2) Make sure that there is no abnormal noise, vibration, or overheating prior to starting operation. If you notice any of these signs, contact your distributor immediately.

■ Transport

- (1) Exercise caution to prevent the dangerous situations arising from this product falling down or rolling over during transport. If suspension fixtures are present, be sure to use the suspension fixtures with the reducer and ensure that the fixtures are not loose. However, once the device is installed, avoid attaching the suspension fixtures to the device and then raising up the entire device by the suspension fixtures. Doing so may lead to damage to the suspension fixtures and to injuries and equipment damage arising from the product falling down or rolling over.
- (2) Prior to suspending the reducer, determine its mass by checking information such as the nameplate, packaging, external diagram, or catalog. Then, do not suspend the reducer if it meets or exceeds the rated load of the suspension fixtures. Doing so may lead to damage to the suspension fixtures and to injuries and equipment damage arising from the product falling down or rolling over. Also, do not place your hands in the terminal box to lift up the product. Doing so may cause the terminal box to fall out.
- (3) If the packaging is a wooden box, the product will be unstable if you use a forklift to scoop up the box from underneath. Instead, wrap a belt around the box and affix this belt to the forklift when raising up the product.
- (4) When transporting the product, insert eye bolts or similar objects into the installation taps on the sides of the housing to suspend the product in a balanced manner.

Servo Motor Mounting Procedure

For smooth motor shafts (input shaft clamp type)

- (1) Set the reducer so that the motor mounting surface is on top.
- (2) Thoroughly wipe away rust, dust, rust-preventive oil, and any other materials from the motor shaft.
- (3) Remove the flange's rubber cap, and then turn the input shaft to align the bolt head with the hole position.
Use an L wrench or similar tool to check that the set bolt is loose.
- (4) Smoothly insert the motor shaft into the input shaft bore. Exercise caution to ensure that the motor shaft is not inserted at an angle.
- (5) After inserting the spigot facing completely, fasten the motor to the flange using the appropriate bolt and tightening torque.
- (6) Use a torque wrench to tighten the set bolt on the input shaft with the specified tightening torque.
- (7) Attach the rubber cap.

This completes the motor set up procedure.

Tightening the set bolt for the clamp specification

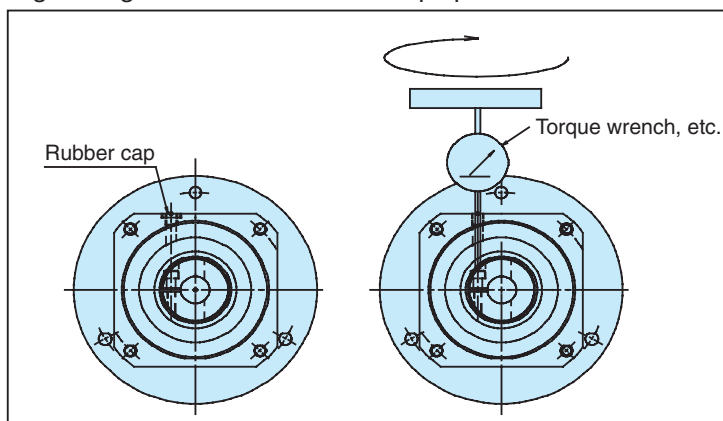

Mounting a keyed/flatted motor on an input shaft clamp type

By removing the key, you can use keyed/flatted motor shafts with a clamp type in the same manner as with smooth shafts. Set the motor's key groove (D cut) on the side 180 degrees away from the clamp slit position. Then, mount the motor on the reducer using the same procedure for smooth shafts.

GMTK/HMTK clamp specification set bolt tightening torque

GMTK			HMTK				Set bolt size	Tightening torque
0218U/L	0224U/L	0228U/L	0220H	0222U	0230H	0228U	M4	4.1N·m(0.41 kgf·m)
0424U/L	0428U/L	0438U/L	0430H	0428U	0435H	0438U		
0728U/L	0738U/L	0742F/L	0735H	0738U	0745H	0742U	M5	8.5N·m(0.85 kgf·m)
1538U/L	1542F/L		1545H	1542U	1555H	1550U		
-			2245H	2242U	2255H	2250U	M6	14 N·m (1.42 kgf·m)

List of SWJMK/SWMK/EWJMK/EWMK clamp set bolt sizes

Worm model no.	Mount code	E4	G2/G5	K2/K3/K4	L1
	Spigot diameter	φ50G7	φ70G7	φ110G7	φ114.3G7/H7
	Mounting pitch	PCD70	PCD90	PCD145	PCD200
EWJMK35, SWJMK35		M3	-	-	-
EWJMK42, SWJMK42		M3	-	-	-
EWJMK50, SWJMK50		-	M4	-	-
EWJMK63, SWJMK63		-	M4	M6	M6
EWJMK70, SWJMK70		-	-	M6	M6
EWMK80, SWMK80		-	-	M6	M6
EWMK100, SWMK100		-	-	-	M6

SWJMK/SWMK/EWJMK/EWMK clamp set bolt tightening torque

Clamp set bolt size	Tightening torque
M3	1.9 N·m (0.19 kgf·m)
M4	3.8 N·m (0.39 kgf·m)
M6	12 N·m (1.22 kgf·m)

Installation

1. Mounting direction

- HMTK, GMTK, SWJMK, and EWJMK

There are no limitations on the mounting direction. The product can be installed horizontally, vertically, or at an angle.

- SWMK and EWMK

For the 80- and 100-size reducers, horizontal is the standard mounting direction. Specify any other mounting directions when ordering.

Mounting

1. Foot mount

- (1) Use a strong and flat mounting surface that is minimally affected by the vibrations during operation. Remove any dirt and foreign materials from the mounting surface, and then use four bolts to securely fix the product in place.
- (2) If you will use coupling to connect the product to another device, securely align the devices. Shaft eccentricity will shorten the service lives of bearings, gears, and shafts and will cause noise and vibrations.
- (3) Correctly align the chains and belts, and adjust their tenseness so that the load applied to the output shaft does not meet or exceed the rated value.
- (4) Note that, when the product is connected to another device, subjecting the output shaft, coupling, pulley, or sprocket to strong impacts may damage the output shaft bearings.

2. Flange mounting

- (1) Use a strong and flat flange mounting surface that is minimally affected by the vibrations during operation. Remove any dirt and foreign materials from the flange mounting surface, and then use four bolts to securely fix the product in place.
- (2) If you will use coupling to connect the product to another device, securely align the devices. Shaft eccentricity will shorten the service lives of bearings, gears, and shafts and will cause noise and vibrations.
- (3) Correctly align the chains and belts, and adjust their tenseness so that the load applied to the output shaft does not meet or exceed the rated value.
- (4) Note that, when the product is connected to another device, subjecting the output shaft, coupling, pulley, or sprocket to strong impacts may damage the output shaft bearings.

3. Face mount

- (1) When mounting the product on a machine, use the case taps.
- (2) If you will use coupling to connect the product to another device, securely align the devices. Shaft eccentricity will shorten the service lives of bearings, gears, and shafts and will cause noise and vibrations.
- (3) Correctly align the chains and belts, and adjust their tenseness so that the load applied to the output shaft does not meet or exceed the rated value.
- (4) Note that, when the product is connected to another device, subjecting the output shaft, coupling, pulley, or sprocket to strong impacts may damage the output shaft bearings.

4. Hollow shaft

4-1. Mounting the product on a driven shaft

- (1) The hollow shaft bore is manufactured such that its tolerance conforms to JIS H8. Normally, the driven shaft is finished to h7. If the shocks or radial load are large, it is finished approximately to js6 or k6 such that it provides a slightly firm fit.
- (2) When mounting the product on a driven shaft, apply molybdenum disulfide grease to the surface of the driven shaft and to the hollow output shaft bore before inserting the driven shaft.
- (3) You can smoothly perform the insertion by manufacturing and using a tool such as that shown to the right.

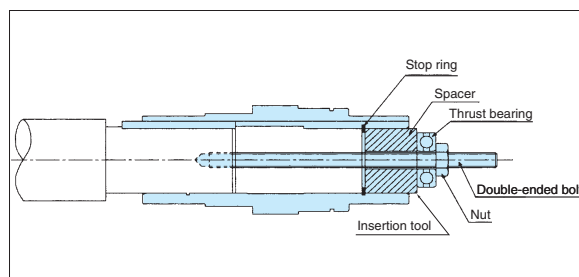

4-2. Fixing the product in place on a driven shaft

- A. When the driven shaft has levels
Manufacture an end plate as shown in the following diagram, and then fix the hollow output shaft and driven shaft in place.

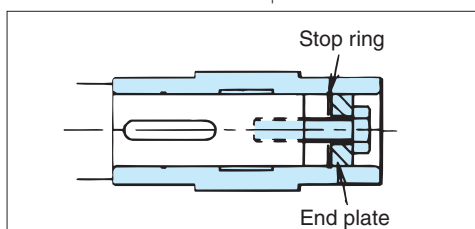

- B. When the driven shaft does not have levels
The following two fixation methods are available.

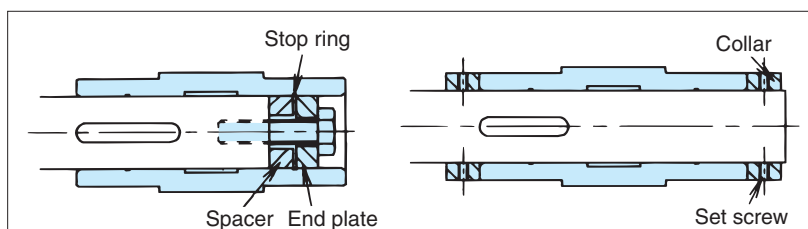

4-3. Torque arm stopper

- (1) Mount the torque arm on the driven machine side of the reducer. Use a hex cap bolt to mount the torque arm on the reducer.
- (2) Ensure that the torque arm stopper is free to move between the reducer and the driven shaft. Never fix the torque arm in place with a stopper bolt. If the torque arm stopper is not free to move, the bearings within the reducer may be damaged.
- (3) When the start frequency is high, when repeated forward and reverse operations are being performed, and in similar situations, attaching rubber bush between the torque arm and the stopper bolt (or the spacer) will alleviate shocks.

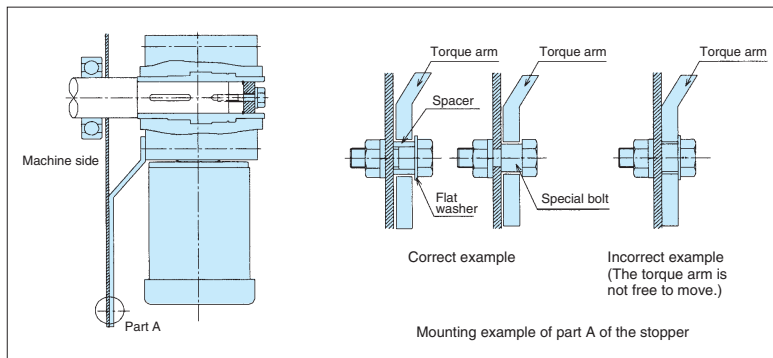

4-4. Removing the product from a driven shaft

- (1) Remove the driven shaft from the hollow output shaft in a manner such that excessive force is not applied between the housing and the hollow output shaft.
- (2) You can smoothly perform the removal by manufacturing and using a tool such as that shown to the right.

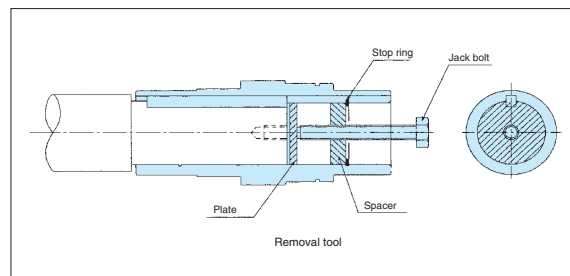

Maintenance

Use your five senses and simple measuring instruments to check the following key points during daily maintenance. It is sufficient to simply pay attention to these points while operating the product.

- Noise... Is the noise louder than usual? Are there any unusual noises that occur periodically?
- Vibrations... Is there any unusual vibration?
- Temperature rises... Is the surface temperature of the reducer higher than normal?

Grease Lubrication (GMTK and HMTK)

1. Grease lubrication

Grease is used to lubricate the product.

2. Already greased

The product is greased with the correct amount of unleaded grease at the time of shipment, so you can use the product without adding additional lubrication.

3. Grease change

In most cases, there is no need to change the grease or add new grease. However, you can increase the service life of the product by changing the grease after—as a guideline—20,000 hours of use.

4. Grease specifications

Use high-grade gear grease equivalent to consistency number 000.

5. Recommended greases

Nippon Grease: NIGTIGHT LMS number 000 (unleaded grease that is the initially included product)

Showa Shell Sekiyu: Alvania EP Grease R000

JX Nippon Oil & Energy: PYRONOC UNIVERSAL 000

* NIGTIGHT is a registered trademark of Nippon Grease Co., Ltd.

Alvania is a registered trademark of Shell Brands International AG.

PYRONOC UNIVERSAL is a registered trademark of ENEOS Corporation.

Oil Lubrication (SWJMK, SWMK, EWJMK, and EWMK)

1. Oil lubrication

Oil is used to lubricate the product.

2. Already oiled

The product is oiled with the correct amount of oil (Daphne Alpha Oil TE260) at the time of shipment, so you can use the product without adding additional lubrication.

3. Oil change

- The 35- to 70-size reducers have an airtight construction, so, in most cases, there is no need to change the lubrication oil or add new lubrication oil. However, if the usage conditions lead to pronounced deterioration of the lubrication oil, you can increase the service life of the product by changing the oil after—as a guideline—2,500 hours of use.
- Perform maintenance on the 80- and 100-size reducers according to the following key points.
 - (1) First change: 1,000 hours or three months after the start of operation, whichever comes first.
 - (2) Subsequent changes: Depending on operating conditions, 5,000 hours or one year, whichever comes first.

4. Pressure vent

- The 35- to 70-size reducers have an airtight construction, so pressure vents are not necessary.
- Check that the 80- and 100-size reducers are installed in the standard mounting direction, and then be sure to install the included pressure vent. After the installation is complete, use the oil gauge to check the oil level. Specify any mounting directions other than the standard mounting direction when ordering.

5. Recommended oil

Lubrication oil is vital to reducer capacity, life, and efficiency.

Use only lubrication oil recommended by Tsubaki. (Never mix the oil with other brands.)

SWJMK and SWMK EWJMK and EWMK	Daphne Alpha Oil TE260 (IDEMITSU)
----------------------------------	-----------------------------------

* Daphne is a registered trademark of Idemitsu Kosan Co., Ltd.

6. Approximate oil volume

SWJMK/SWMK

Unit: L

Size \ Type		Type						
		SWJMK35	SWJMK42	SWJMK50	SWJMK63	SWJMK70	SWMK80	SWMK100
Mounting direction	E	0.10	0.16	0.55	0.95	1.3	–	–
	B	–	–	–	–	–	1.0	1.4
	T	–	–	–	–	–	1.8	2.8
	V	–	–	–	–	–	1.4	2.1

EWJMK/EWMK

Unit: L

Size \ Type		Type						
		EWJMK35	EWJMK42	EWJMK50	EWJMK63	EWJMK70	EWMK80	EWMK100
Mounting direction	E	0.17	0.29	0.55	0.95	1.0	–	–
	B	–	–	–	–	–	1.2	1.7
	T	–	–	–	–	–	1.2	1.7
	V	–	–	0.55	0.95	1.0	1.7	2.8

Oil Seals

Reducers use contact-type oil seals. In most cases, there is no need to change the oil seals. However, you can increase the service life of the reducer by changing the oil seals after—as a guideline—10,000 hours of use. The service lives of oil seals vary depending on the usage conditions, so you may have to change them even within 10,000 hours of use.

Also, when using the product with food processing machines, especially those devices with which oil must not be used, install an oil pan or other damage prevention equipment to prepare for the rare occurrences of oil spills caused by issues such as malfunctions and the oil seals reaching the end of their service lives.

*Occasionally, during the early period after operation starts, grease filled during the assembly process may seep out of the oil seal lip. This is normal and does not affect the performance of the reducer.

Inquiry Form

1. Machine and application

(1) Machine name

(2) Application

* To explain your application in detail, attach a layout drawing and any other relevant application study documents.

2. Drive motor

(1) Manufacturer

(2) Series, model number

(3) Rated output capacity kW

(4) Rated speed r/min

(5) Rated torque N·m

(6) Maximum speed r/min

(7) Maximum torque %

3. Motion profile

Load torque: T
Input speed: n

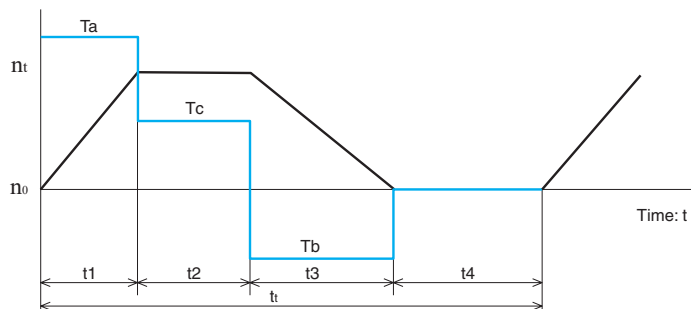

(9) Output part dimensions

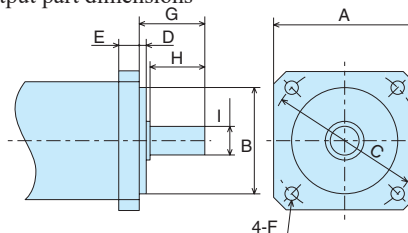

Dimension entry fields

Flange dimensions						Shaft tip dimensions		
A	B	C	D	E	F	G	H	I
130	φ110h7	145	3	12	φ9	55	50	φ24h6

□ indicates example entries. Enter the information in the same manner as these examples. For keyed/flatted products, enter the key dimensions and length. When an oil seal is included, clearly indicate this, and enter the dimensions.

Motion profile (entry example)

Time	Operating mode	Input speed	Load torque
sec		r/min	N·m
t1	Acceleration	$n_0 \rightarrow n_t$	T_a
t2	Constant speed	n_t	T_c
t3	Deceleration	$n_t \rightarrow n_0$	T_b
t4	Stopped	n_0	0

Motion profile (entry example)

Time	Operating mode	Input speed	Load torque
sec		r/min	N·m

4. Reducer specifications and operating conditions

(1) Output shaft style Parallel solid shaft Right-angle solid shaft Right-angle hollow shaft

(2) Gear head style Helical gear head Hypoid gear head Worm gear head

(3) Reduction Ratio

(4) Output shaft load Radial load () N Axial load () N

(5) Output shaft connection Coupling Gear Belt pulley Other ()

(6) Mounting style Foot mount Flange mount Torque arm mount

(7) Installation location Indoors Outdoors

(8) Ambient temperature (9) Expected service life: hours

MEMO

Introduction to the Easy Sizing Website (Selection Tool)

Our website provides a tool for easily selecting servo motors from various manufacturers and the corresponding reducers. The same website also provides downloadable PDF drawings and CAD file drawings in DXF and 3D formats.

<https://tsubakimoto.com/power-transmission/reducer/servo-motor/reducer/>

Power Transmission Products ▾

- Drive Chains
- Small Size Conveyor Chains
- Large Size Conveyor Chains
- Top Chains
- Sprockets
- Hose and Cable Carrier System
- Timing Belts
- Timing Pulleys
- Reducer
 - ◆ Gear Box
 - ◆ Servomotor Reducer
 - ▶ Servomotor Reducer
 - ◆ Gear Motor
- Locking Device
- Shaft Coupling
- Linear Actuator
- Clutch
- Electrical Controllers
- Mechanical Protectors
- Examples of Use by Industry and Application

Servomotor Reducer

Servomotor Reducer



Extensive line of reducers suitable for advanced motion control by servo motors

Our TERVO Series is capable of deployment in a wide range of servomotor applications; A reasonably priced, multipurpose servo gear head with a broad gear line-up.

Product Inquiries

[Contact](#)





Product News

2018.10.01 Notice regarding product discontinuation: We are discontinuing sales of some models on June 30, 2019.

2017.07.03 Notice regarding discontinuation of High Precision Planetary Gearbox for PAT-B Series: We are discontinuing sales of High Precision Planetary Gearbox for Servo Motors (Tsubaki PAT-B Series) as follows.

Product Lineup

■ General-Purpose Reducer for Servo Motors: TERVO

Product Types / Features	
	<p>Hypoid Gear Head HMTK</p> <ul style="list-style-type: none"> · Right-angle shaft type with high efficiency · Hollow or solid output shaft · Applied servomotor: 0.2 to 2kW, Reduction Ratio: 1/5 to 1/200 <p style="text-align: right;">Details</p>
	<p>Helical Gear Head GMTK-L</p> <ul style="list-style-type: none"> · Parallel shaft type with high efficiency · Solid output shaft, foot mounting · Applied servomotor: 0.2 to 2kW, Reduction Ratio: 1/5 to 1/200 <p style="text-align: right;">Details</p>
	<p>Helical Gear Head GMTK U, F</p> <ul style="list-style-type: none"> · Parallel shaft type with high efficiency · Solid output shaft, flange and face mounting · Applied servomotor: 0.2 to 2kW, Reduction Ratio: 1/5 to 1/200 <p style="text-align: right;">Details</p>
	<p>Worm Gear Head SWJMK, SWMK</p> <ul style="list-style-type: none"> · Right-angle shaft type, high strength and quiet operation · Hollow output shaft · Applied servomotor: 0.2 to 7kW, Reduction Ratio: 1/10 to 1/60 <p style="text-align: right;">Details</p>
	<p>Worm Gear Head EWJMK, EWMK</p> <ul style="list-style-type: none"> · Right-angle shaft type, high strength and quiet operation · Solid output shaft · Applied servomotor: 0.2 to 7 kW, Reduction Ratio: 1/10 to 1/60 <p style="text-align: right;">Details</p>

Click here!!



Safety Precautions



CAUTION

(General)

- Comply with the required safety regulations where the reducer is set or used. (Ordinance on Labor Safety Law by government, electrical system technical standards, building standard laws, etc.)
- To ensure optimum performance is obtained from the product, it is necessary to read and understand the instructions and safety precautions contained in the manual.

If the instruction manual is not at hand, request one from the distributor where you purchased the product, or Tsubakimoto Chain Co. with product name and model number.

This manual should remain with the product at all times, including when redistributed.

Make sure this manual is available to every person who operates the product.

(Selection)

- Select the products which are suitable for the usage environment and application.
- When using with equipment for transporting humans or an elevating device, install a suitable protection device on the equipment for safety purposes. Otherwise an accident resulting in death, injury or damage to the equipment may occur due to accidental falling.
- Use explosion-proof type motors in an explosive atmosphere. Use an explosion-proof type motor suitable for dangerous environments to prevent possible explosions, ignitions, electrical shock, injuries, fires and damage to the device.
- When the product is used for food processing machinery, install devices such as oil pans to prevent grease from leaking. Lubricant oil can damage food or other such products.

Warranty:

Tsubakimoto Chain Co.: hereinafter referred to as "Seller"

Customer: hereinafter referred to as "Buyer"

Goods sold or supplied by Seller to Buyer: hereinafter referred to as "Goods"

1. Warranty period without charge

18 months effective the date of shipment or 12 months effective the first use of Goods, including installation of Goods to Buyer's equipment or machine - whichever comes first.

2. Warranty coverage

Should any damage or problem with the Goods arise within the warranty period, given that the Goods were operated and maintained according to the instructions provided in the manual, Seller will repair and replace at no charge once the Goods are returned to the Seller.

This warranty only covers individual Goods supplied by the Seller to the Buyer and therefore does not include the following:

- (1) Any costs related to the removal or re-installation of Goods from the Buyer's equipment or machine to repair or replace parts.
- (2) Cost to transport Buyer's equipment or machines to replace or repair.
- (3) Costs to reimburse any profit loss due to any repair or damage and consequential losses caused by the Buyer.

3. Warranty with charge

Seller will charge for any investigation and repair of Goods (even during the warranty period without charge) caused by:

- (1) Improper installation by failing to follow the instruction manual.
- (2) Insufficient maintenance or improper operation by the Buyer.
- (3) Incorrect installation of Goods onto other equipment or machines.
- (4) Structure change of the Goods by any modifications or alterations by the Buyer.
- (5) Any repair by engineers other than the Seller or those designated by the Seller.
- (6) Operation in an inappropriate environment not specified in the manual.
- (7) Force Majeure or forces beyond the Seller's control such as a natural disaster and injustices committed by a third party.
- (8) Secondary damage or problems incurred by the Buyer's equipment or machines.
- (9) Defective parts supplied or specified by the Buyer.
- (10) Wear, tear or deterioration of parts including bearings and oil seals.
- (11) Loss or damage not liable to the Seller.



CAUTION

Product details described in this catalog are primarily intended to aid product selection. Always read the instruction manual before using any product to ensure correct use.



TSUBAKIMOTO CHAIN CO.

Japan	Tsubakimoto Chain Co.	https://tsubakimoto.com/
-------	-----------------------	---

Global Group Companies

AMERICAS

United States	U.S. Tsubaki Power Transmission, LLC	https://www.ustsubaki.com/
Brazil	Tsubaki Brasil Equipamentos Industriais Ltda.	https://tsubaki.ind.br/
Canada	Tsubaki of Canada Limited	https://tsubaki.ca/

EUROPE

Netherlands	Tsubakimoto Europe B.V.	https://tsubaki.eu/
France	Kabelschlepp France S.A.R.L.	https://tsubaki-kabelschlepp.com/fr-fr/
Germany	Tsubaki Deutschland GmbH Tsubaki Kabelschlepp GmbH	https://tsubaki.de/ https://tsubaki-kabelschlepp.com/de-de/
Italy	Kabelschlepp Italia S.R.L.	https://tsubaki-kabelschlepp.com/it-it/
Spain	Tsubaki Ibérica Power Transmission S.L.	https://tsubaki.es/
United Kingdom	Tsubakimoto UK Ltd.	https://tsubaki.eu/
Slovakia	Kabelschlepp-Systemtechnik, spol. s.r.o.	https://tsubaki-kabelschlepp.com/sk-sk/
Poland	Kabelschlepp Sp. z o.o.	https://kabelschlepp.pl/

INDIAN OCEAN RIM

Singapore	Tsubakimoto Singapore Pte. Ltd.	https://tsubaki.sg/
Australia	Tsubaki Australia Pty. Limited	https://tsubaki.com.au/
India	Tsubaki India Power Transmission Private Limited	https://en.tsubaki.in/
Indonesia	PT. Tsubaki Indonesia Trading	https://tsubaki.id/
Malaysia	Tsubaki Power Transmission (Malaysia) Sdn. Bhd.	https://en.tsubaki.my/
New Zealand	Tsubaki Australia Pty. Limited - New Zealand Branch	https://tsubaki.com.au/
Philippines	Tsubakimoto Philippines Corporation	https://en.tsubaki.ph/
Thailand	Tsubakimoto (Thailand) Co., Ltd.	https://tsubaki.co.th/
Vietnam	Tsubakimoto Vietnam Co., Ltd.	https://tsubaki.net.vn/

EAST ASIA

Republic of Korea	Tsubakimoto Korea Co., Ltd.	https://tsubakimoto-tck.co.kr/
Taiwan	Taiwan Tsubakimoto Trading Co., Ltd.	https://tsubakimoto.tw/

CHINA

China	Tsubakimoto Chain (Shanghai) Co., Ltd.	https://www.tsubaki-sh.cn/
-------	--	---
