

Enhanced Lineup

TSUBAKI Plastic Modular Chain WT6306-W

Top Chain



For heavy-load, long-length conveyors

ALL PLAST

Our line of plastic modular chains for vehicle assembly man conveyors now includes the new WT6306-W chain. This all-plastic chain is easy to handle and offers high allowable load, making it ideal for heavy-load, long-length applications.

The highest allowable load ever among Tsubaki plastic modular chains allows long-length conveyors exceeding 100 meters

This heavy-duty chain has a chain pitch of 63.5 mm and a chain link thickness of 30.0 mm. Its excellent load-bearing elongation performance (rigidity) effectively suppresses pulsation. And because it is made entirely of plastic, it is approximately 25% lighter than competitors' products with stainless steel pins.

■ Comparison of allowable load with existing Tsubaki products

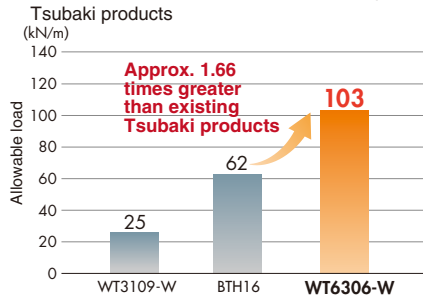

■ Number of vehicles vs. allowable load

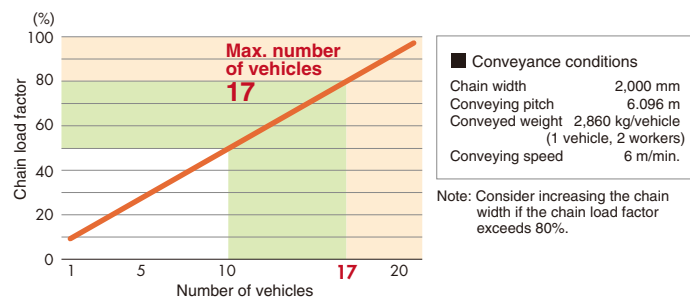

Note: The wheel chocks are yellow and are made of standard non-antistatic material.

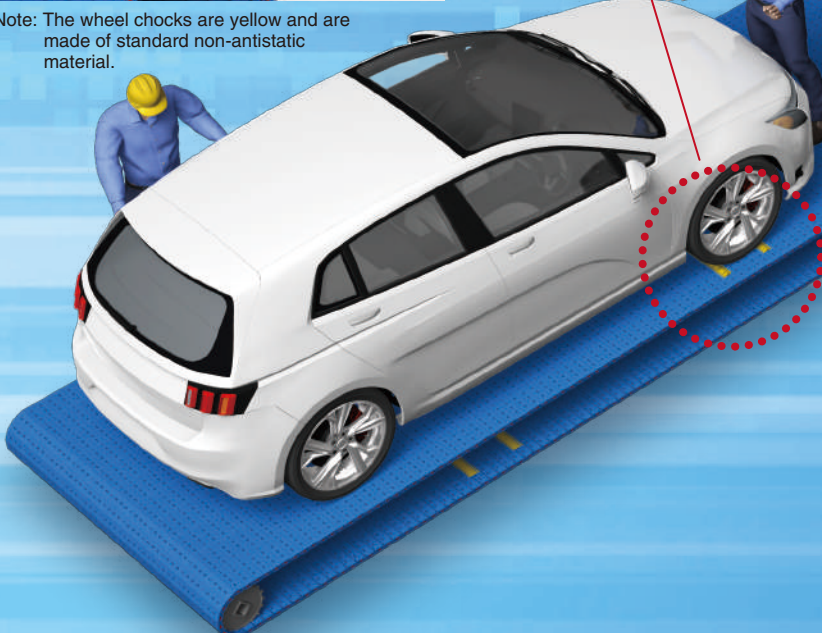

Optional wheel chock links available

Used in combination with the WT6306-W, wheel chocks help to keep the vehicles in place. To ensure high visibility, they are colored yellow.

Note: Wheel chock-incorporated chains are made to order.

IC CHAIN

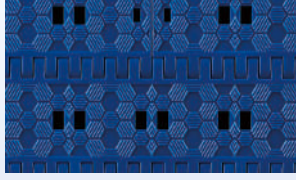

The perforated plate surface drains water easily, preventing water from collecting on the surface.



Patent registered

Non-skid surface ensures worker safety

A special surface design ensures worker safety and improves the maneuverability of trolleys.

Note: When using chains for transporting personnel, such as in man conveyors, detailed usage information for the chain and a safety confirmation document must be obtained in accordance with the Product Liability Act.

Drainage holes on the plate surface allow use in wet environments

The chain has holes on the plate surface, allowing water to drain. This makes the chain suitable for use in environments where it is exposed to water, such as shower testers.

Antistatic link material adopted as standard

Using in combination with antistatic UHMW-PE wearstrips (10-806) reduces the generation of static electricity caused by friction.

Note: The wheel chocks are not antistatic.

Excellent maintainability allows users to do partial repairs themselves

No special tools are required for splicing thanks to the slide plugs.

Usage examples

Assembly line

Vehicles and workers can be transported simultaneously during the assembly process, such as the installation of doors and interior parts.



Inspection line

Visual inspection and water leak tests (using a shower tester) of completed vehicles can be done on a single conveyor.



Plastic Modular Chain WT6306-W

Straight running wide type

Open type

High strength

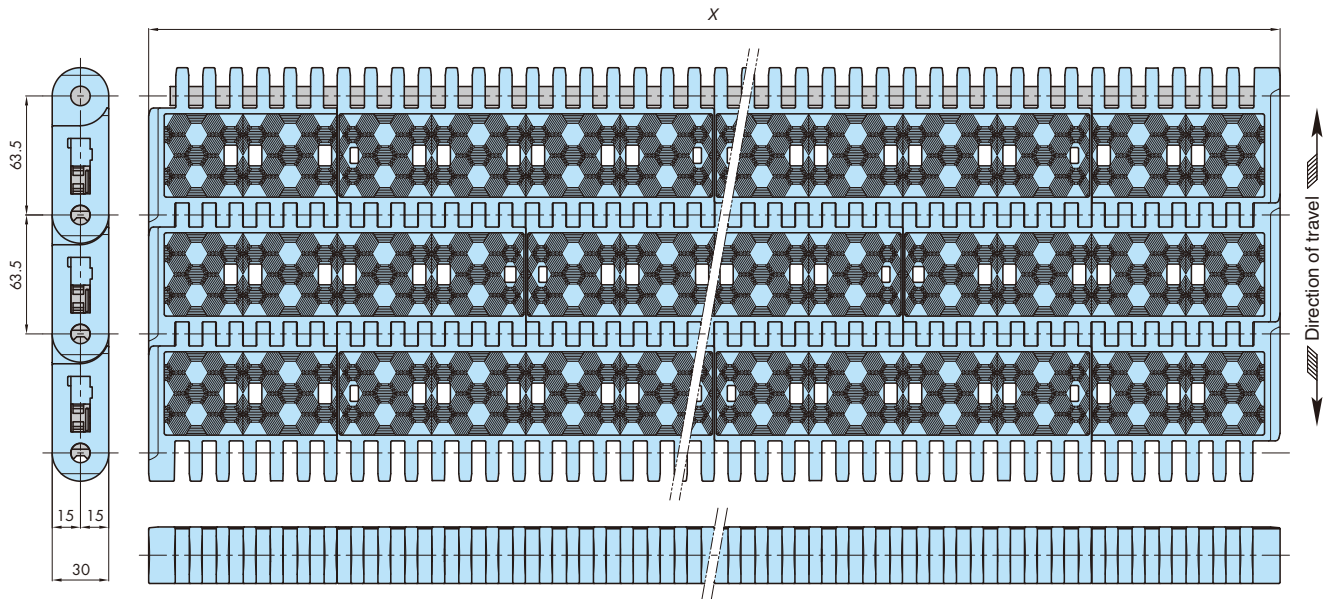

Chain pitch mm	Open area %	Backflex radius mm
63.5	5	75

Chain material table

Type	Material	Material mark	Color	Max. allowable load kN/m{kgf/m}	Chain mass kg/m	Max. allowable speed m/min		Operating temperature range °C	Pin material
						With lube	No lube		
WT6306	Standard (with antistatic properties)	B	Blue	103 {10510}	30.3	15		-20 to (60) 80	Special engineering plastic

- Note: 1. Made to order (RFQ). For specifications not listed above, please contact a Tsubaki representative.
 2. If you are considering this chain, please fill in the inquiry form on page 6 and contact a Tsubaki representative.
 3. The maximum allowable load indicates the value specified for room temperature (20°C) when loads are evenly applied to the entire surface of the chain in a widthwise direction. The maximum allowable load shown in the above chain material table is specified in a unit of 1 m chain width. Calculate the maximum allowable load of the chain to be examined by multiplying the maximum value per meter by its width X.
 4. The value in parentheses in the operating temperature range applies to wet conditions.

Tsubaki model table

Chain width X	Standard B Model number	Chain width X	Standard B Model number	Chain width X	Standard B Model number	Chain width X	Standard B Model number
400	WT6306-W400-B	1400	WT6306-W1400-B	2400	WT6306-W2400-B	3400	WT6306-W3400-B
600	WT6306-W600-B	1600	WT6306-W1600-B	2600	WT6306-W2600-B	3600	WT6306-W3600-B
800	WT6306-W800-B	1800	WT6306-W1800-B	2800	WT6306-W2800-B	3800	WT6306-W3800-B
1000	WT6306-W1000-B	2000	WT6306-W2000-B	3000	WT6306-W3000-B	4000	WT6306-W4000-B
1200	WT6306-W1200-B	2200	WT6306-W2200-B	3200	WT6306-W3200-B		

- Note: 1. Chain widths can be configured in 100-mm increments, starting from 400 mm to 4,000 mm.
 2. Chain width X shown is a nominal width. Actual width range is X - 0.6% at 20°C operating temperature (for Standard B chain). Chain width is subject to expansion or contraction with changes in temperature. The expansion/contraction rate is 0.00012/°C based on a temperature of 20°C (for Standard B chain).
 3. When using in personnel transport equipment, be sure to install safety guards on the equipment side.
 4. When using chains for transporting personnel, such as in man conveyors, detailed usage information for the chain and a safety confirmation document must be obtained in accordance with the Product Liability Act.

Model numbering example

Chain type	Chain pitch	Link shape	Chain width	Material mark	Number of links	Unit
WT	63	06	- W1200	- B	+ 80	L
	63: 63.5 mm	6: Open type	Note 2		Note 3	L: Link

- Note: 1. No space is required between the letters and symbols.
 2. Please refer to the Tsubaki model table above for chain widths.
 3. Minimum quantity 2; maximum quantity 99,999.

Keeps vehicles
in place

Wheel chocks

Enhanced lineup

In transporting completed vehicles, incorporating wheel chocks into the main chain modules supports accurate positioning of the vehicles. To ensure high visibility, the wheel chocks are colored yellow.

Note: Wheel chock-incorporated chains are made to order.



The gentle semicircular shape allows vehicles to run over it smoothly.



We also offer 25-mm-high wheel chocks, which give a clearer sensation of the vehicles running over them. For smooth running-over, the wheel chock is designed in a trapezoidal shape.

Wheel chocks for WT6306-W

Wheel chock height **12.5 mm**

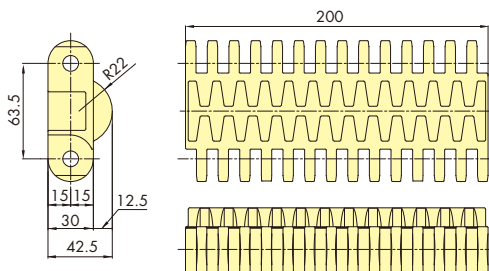

Wheel chock height **25 mm**

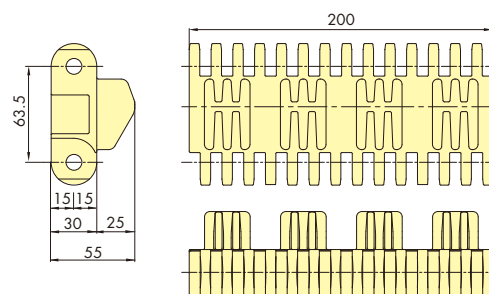

● Wheel chock configuration diagram (reference)

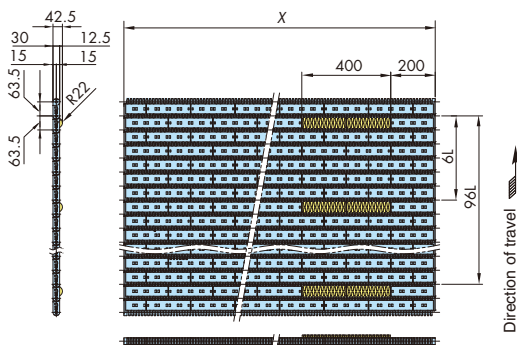

● Wheel chock configuration diagram (reference)

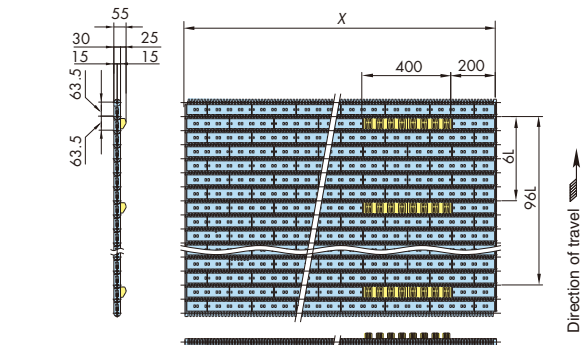

The above diagrams are examples. The position and spacing of the wheel chocks should be discussed on a case-by-case basis, as each situation is unique.

Model numbering example

Chain type	Chain pitch	Link shape	Wheel chock	Chain width	Material mark	Wheel chock spacing	Special configuration
WT	63	06	CH25 - W1200	- B -	96	LA	- TK
	63: 63.5 mm	6: Open type	CH12: Wheel chock height 12.5 mm CH25: Wheel chock height 25 mm			96LA: Mounted every 96 links	

- Note: 1. No space is required between the letters and symbols.
2. Wheel chock-incorporated chains are made to order.
3. Chain widths can be configured in 100-mm increments, starting from 400 mm. However, when incorporating wheel chocks, we recommend configuring the chain width in 200-mm increments.

Sprockets for WT6306-W

Solid sprockets (machined)

WT-S6300-16T

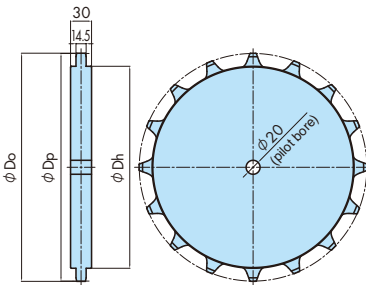

WT-S6300-18T

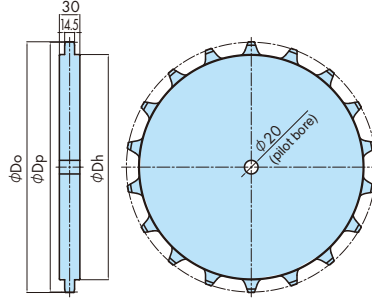

WT-S6300-20T

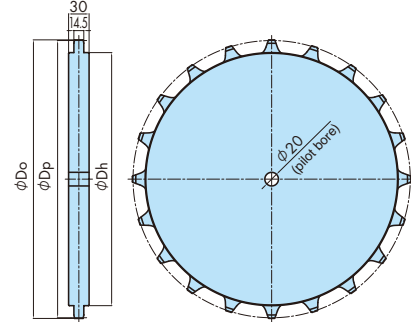

Model number	Number of teeth	Pitch circle diameter D_p	Outer diameter D_o	Hub diameter D_h	Shaft bore shape	Material
WT-S6300-16T	16	325.49	326.2	289	The standard shape is square, but we can manufacture other shapes upon request.	Polyamide (blue)
WT-S6300-18T	18	365.68	367.1	330		
WT-S6300-20T	20	405.92	407.9	371		

Note: 1. Made to order (RFQ).
 2. Operating temperature range: -20°C to 60°C
 3. We can also manufacture sprockets with different tooth counts, shapes, and materials than those listed above. Contact a Tsubaki representative for details.

Wearstrip layout example

- 1 We will provide proposals during the chain selection process.
- 2 We recommend plastic wearstrips, as they are expected to reduce sliding resistance, wear, and pulsation. Because plastic chains inevitably generate static electricity, we recommend the antistatic UHMW-PE wearstrip (10-806).
- 3 The wearstrips should be installed in sections.
- 4 Clearance must be provided to allow for expansion and contraction of the plastic due to temperature changes.
- 5 When attaching the plastic wearstrips, do not fix them completely; instead, use spacers or other methods to maintain a gap between the wearstrip and conveyor.
- 6 If trolleys or similar equipment pass over the sprockets, machine a recess at the wearstrip ends to prevent interference with the sprockets. Care must be taken to prevent the chain from sagging.
- 7 Contact a Tsubaki representative for wearstrip details.

● Wearstrip layout example (conveying side)

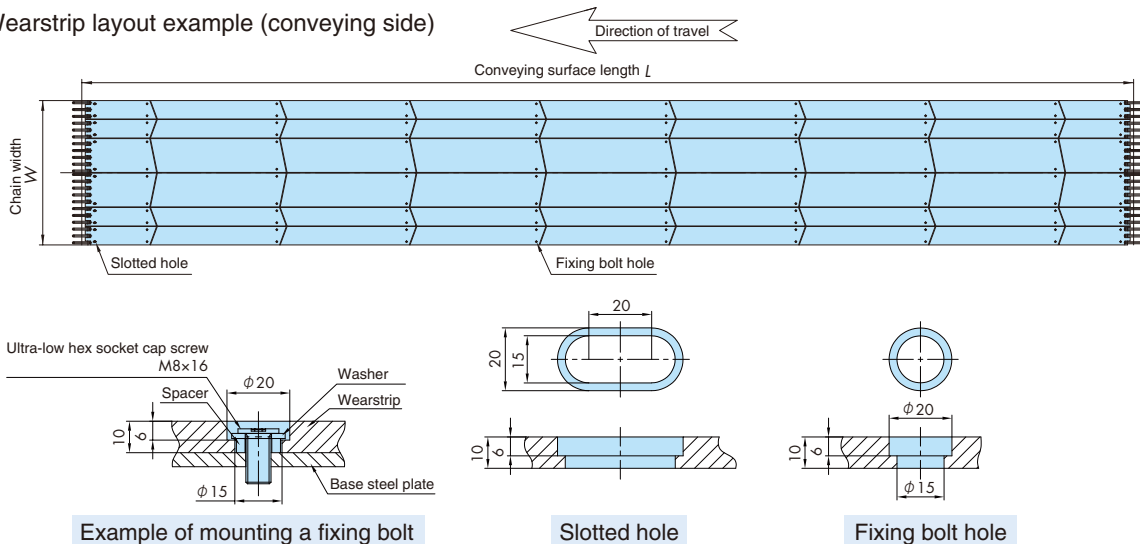

Example of mounting a fixing bolt

Slotted hole

Fixing bolt hole

Company name		Your name	
Contact number (phone/fax)		Email	
Equipment/application/process			
1. Conveyed items	1) Conveyed items (multiple selections allowed)	Vehicles · Workers · Trolleys · Other ()	
	2) Mass	kg × units,	kg × persons
	3) Vehicle dimensions	Overall length: mm · Overall width: mm · Tread width: mm	
2. Conveyor specifications	1) Conveying surface length	m	
	2) Width	mm (100-mm increments, starting from 400 mm)	
	3) Layout	Type 1 · Type 2 · Type 3 · Other: Contact a Tsubaki representative.	
	4) Number of conveyor lanes	1 (wide) · 1 (single-sided) · 2 (double-sided, overall width mm)	
	5) Wheel chocks	No · Yes () Note: If yes, please specify the position and spacing of the wheel chocks. See p4.	
	6) Wheel chock height	12.5 mm · 25 mm · Other ()	
	7) Idler motor	No · Yes	
	8) Drive/idler shaft material	SS400 · SUS	
3. Conveyance conditions	1) Conveying speed	m/min	
	2) Takt operation	No · Yes (indexing length of 1 takt mm, indexing time of 1 takt s)	
	3) Lubrication	No · Yes (water · other ())	
	4) Operating time	hours/day, days/year	
	5) Wearstrip material	Antistatic UHMW-PE (10-806) · Steel (stainless steel) Note: We recommend plastic wearstrips, as they are expected to reduce sliding resistance, wear, and pulsation. Because plastic chains inevitably generate static electricity, we recommend the antistatic UHMW-PE wearstrip (10-806).	
	6) Return-side support method	Rollers · Wearstrips	
	7) Conveying pitch	mm	
4. Operating environment	1) Temperature/humidity	Room temperature and humidity · Other (°C, % RH)	
	2) Indoor/outdoor	Indoor · Outdoor	
	3) Corrosive conditions (chemicals, disinfectants, detergents, etc.)	Chemicals: No · Yes (name (concentration %, frequency times/)) Water : No · Yes	
	4) Presence of abrasive materials	No · Yes (Metal powder · Sand · Other ())	
	5) Other	Volatile gases: No · Yes ()	

Layout examples

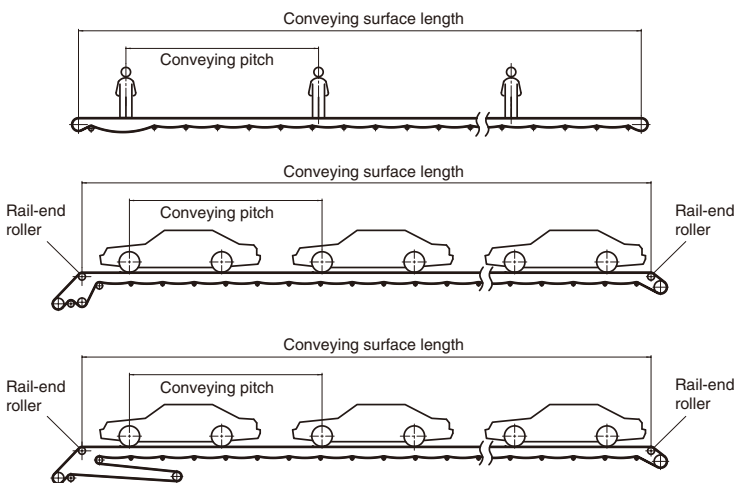

Type 1

The most standard, in an oblong layout, with sprockets installed at both ends. Primarily intended for use with man conveyors.

Type 2

Recommended for use in vehicle assembly applications, such as automobiles or heavy-duty trolleys. This layout prevents vertical loads from being applied directly to the sprocket shaft by routing the drive and driven sections to the bottom via the rail-end rollers. No mechanical take-up unit is used.

Type 3

Recommended for use in vehicle assembly applications, such as automobiles or heavy-duty trolleys. This layout prevents vertical loads from being applied directly to the sprocket shaft by routing the drive and driven sections to the bottom via the rail-end rollers. A mechanical take-up unit is used. Use this configuration in systems with a predefined conveying cycle, such as those equipped with wheel chocks.



TSUBAKIMOTO CHAIN CO.

Japan Tsubakimoto Chain Co. <https://tsubakimoto.com/>

Global Group Companies

AMERICAS

United States U.S. Tsubaki Power Transmission, LLC <https://www.ustsubaki.com/>
Brazil Tsubaki Brasil Equipamentos Industriais Ltda. <https://tsubaki.ind.br/>
Canada Tsubaki of Canada Limited <https://tsubaki.ca/>

EUROPE

Netherlands Tsubakimoto Europe B.V. <https://tsubaki.eu/>
France Kabelschlepp France S.A.R.L. <https://tsubaki-kabelschlepp.com/fr-fr/>
Germany Tsubaki Deutschland GmbH <https://tsubaki.de/>
Tsubaki Kabelschlepp GmbH <https://tsubaki-kabelschlepp.com/de-de/>
Italy Kabelschlepp Italia S.R.L. <https://tsubaki-kabelschlepp.com/it-it/>
Spain Tsubaki Ibérica Power Transmission S.L. <https://tsubaki.es/>
United Kingdom Tsubakimoto UK Ltd. <https://tsubaki.eu/>
Slovakia Kabelschlepp-Systemtechnik, spol. s.r.o. <https://tsubaki-kabelschlepp.com/sk-sk/>
Poland Kabelschlepp Sp. z o.o. <https://kabelschlepp.pl/>

INDIAN OCEAN RIM

Singapore Tsubakimoto Singapore Pte. Ltd. <https://tsubaki.sg/>
Australia Tsubaki Australia Pty. Limited <https://tsubaki.com.au/>
India Tsubaki India Power Transmission Private Limited <https://en.tsubaki.in/>
Indonesia PT. Tsubaki Indonesia Trading <https://tsubaki.id/>
Malaysia Tsubaki Power Transmission (Malaysia) Sdn. Bhd. <https://en.tsubaki.my/>
New Zealand Tsubaki Australia Pty. Limited - New Zealand Branch <https://tsubaki.com.au/>
Philippines Tsubakimoto Philippines Corporation <https://en.tsubaki.ph/>
Thailand Tsubakimoto (Thailand) Co., Ltd. <https://tsubaki.co.th/>
Vietnam Tsubakimoto Vietnam Co., Ltd. <https://tsubaki.net.vn/>

EAST ASIA

Republic of Korea Tsubakimoto Korea Co., Ltd. <https://tsubakimoto-tck.co.kr/>
Taiwan Taiwan Tsubakimoto Trading Co., Ltd. <https://tsubakimoto.tw/>

CHINA

China Tsubakimoto Chain (Shanghai) Co., Ltd. <https://www.tsubaki-sh.cn/>



The Tsubaki Eco Link logo is used only on products that satisfy the standards for environmental friendliness set by the Tsubaki Group.

The logos, brand names, or product names in this catalog are trademarks or registered trademarks of Tsubakimoto Chain Co. and/or its subsidiaries and/or affiliates in Japan and/or other countries.